

USER GUIDE

SERIES 490 MINI-ANEMOMETER



TABLE OF CONTENTS

- SECTION 1** Description
- SECTION 2** Principal of Operation
- SECTION 3** Operating Instructions
- SECTION 4** Applications
 - A. Air Velocity in Open Spaces
 - B. Ventilation Openings
 - C. Velocity and Flow Rates in Small Ducts
 - D. Wind Speed Measurements
- SECTION 5** Specifications
- SECTION 6** Replacement

RELEASE NO. 2 00
AUGUST 1987
© KURZ INSTRUMENTS, INC.

SECTION 1

Description

Kurz's 490 Series is a rugged line of Electronic Velocity Meters that, through the use of low power consumption technology, are powered by four ordinary alkaline AA cells. This makes the units compact enough to be carried in one's pocket, with up to 50 hours of use (four months of typical operation) obtainable from four easy-to-remove cells. Cell replacement is accomplished by removing the meter cover. The 490 uses our advanced low-power sensor, which exhibits extraordinary sensitivity and resistance to shock and vibration. The non-conductive graphite probe shaft is extremely strong; we have never seen a broken probe. Dual ranges are standard: for example, the Model 490 has ranges of 0-200 fpm and 0-2,000 fpm. Also available are metric, feet-per-second and mile-per-hour scale versions, all capable of covering velocities up to 12,000 sfpm (200 sfps).

To use the Mini-Anemometer, the sensor is simply placed in the direction of flow and the meter indication is read. Range selection, battery check and power "OFF" are indicated on the recessed switch plate at the "probe end" of the meter.



SERIES 490
With Carrying Case



SERIES 490
In Operation

SECTION 2

Principles of Operation

The basic sensing element is the **Kurz** unique low-power "**DuraFlo-LP**" probe, which consists of a velocity sensor and a temperature sensor. The velocity sensor is heated and operated as a constant-temperature thermal anemometer which responds to "standard" velocity or mass flow by sensing the cooling effect of the air as it passes over the heated velocity sensor. The temperature sensor accurately compensates for a wide range of ambient temperature variations.



Because it is large and constructed in a coil configuration, the unit is shock and vibration resistant, and insensitive to contamination as well.

It should be noted that the velocity readings of all **Kurz** Air Velocity Meters are referenced to standard conditions: 25° degrees C and 760 mm Hg barometric pressure. Therefore, the measure local mass velocity of the air (standard barometric pressure). In order to obtain the actual velocity, the following density correction formula may be used:

$$V_{act} = V_{ind} \times \rho_s / \rho_a$$

Where ρ_s = air density at standard conditions of 25°C and 760 mm Hg

ρ_a = actual air density at local temperature and barometric pressure, and

V_{act} = actual air velocity in feet-per-minute

V_{ind} = indicated velocity on **Kurz** Air Velocity Meters

Normally, this correction is small and may be neglected in most instances. In fact, most applications require only the mass velocity, with no density calculations being required.

SECTION 3

Operating Instructions

Operation of the series 490 is simple. Before taking a measurement, check the battery voltage by moving the slide-switch to the "BAT" position and observing the scale. The needle must be above the scale symbol for meter readings to be accurate. Next, slide the switch to the "HIGH" position, slide the protective shield back from the probe window, and position the probe so that the air flows through the window and across the sensor. If sufficient resolution is achieved, slide the switch to the "LOW" position and make a reading. The lower side of the scale corresponds to the "LOW" position and the upper side corresponds to the "HIGH" position.

The red LED immediately to the right of the meter scale is illuminated when power is on. The LED serves as a reminder to switch off the unit when it is not in use.



Model 491 Scale

SECTION 4

Applications

A. Air Velocities in Open Spaces or Single-Point Measurements

The 490 series can easily be used to measure local air velocities in a wide variety of applications. The window in the probe tip should be oriented such that the flow passes directly through it. You will notice that the output is relatively unaffected by angular rotation of the probe until the angle approaches ± 30 degrees to the flow direction.

In situations in which the air temperature is changing, allow the probe to reach thermal equilibrium, thus allowing the temperature-compensation features of the meter to respond.

B. Ventilation Openings

The 490 Series Air Velocity Meters can be conveniently used to obtain the velocity and total flow of supply and return openings, as well as suction openings. In either case, place the probe near the surface of the opening and parallel to it, allowing air to flow perpendicularly through the window at the probe tip.

When it is necessary to obtain the total flow (SCFM) of a supply or return opening without a grill, use the following equation:

$$Q = A \bar{V}, \text{ where}$$

Q = quantity of air in standard cubic feet per minute (SCFM)

A = area of the opening in square feet

\bar{V} = the area-weighted average air velocity in standard feet-per-minute (SFPM)

To determine the average air velocity, divide the opening into a number of equal areas. Take a velocity reading at the center of each area and numerically average the results. If the velocity profile is relatively flat, only a few areas need to be taken; if the profile is non-uniform, several areas should be used. Generally, it's a good idea to make a traverse across the duct in both directions to determine the uniformity of the air velocity. If the velocity is not constant at one measuring point, use the mean velocity between the upper and lower readings. Generally, the velocity profile is more uniform on suction openings than on supply openings.

If a supply opening is covered by a grill, it is suggested that the probe be placed about one inch in front of the grill to obtain the average velocity reading as above. The area (A) used in the above equation is the core area of the grill.

If information is given on the coefficient of discharge for a specific grill, the probe should be placed against the grill and centered over the open areas in the grill. Choose several grill openings to obtain an average air velocity. In this case, the total flow is given by:

$$Q = K A \bar{V}, \text{ where}$$

K = the given coefficient of discharge, and

A = the area of the grill as specified by the manufacturer

For openings covered by diffusers, refer to the manufacturer's instructions for the particular type of diffuser. This information is usually available.

Once the average velocity is known, the flow rate can be calculated as follows:

$$Q = \bar{V} A, \text{ where}$$

Q = flow rate in standard cubic feet-per-minute

\bar{V} = average velocity in standard feet-per-minute, and

A = area of duct in square feet

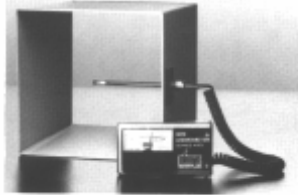

D. Wind Speed Measurements

The series 490 can be readily used for a wide variety of wind speed measurements such as meteorological studies and sporting activities (e.g. sailing, golf, track & field, etc.). Using the 490 in these activities is the same as described in paragraph "A" above.

Example of the 490 being installed in a duct via the PMA-4 Probe Mounting Adapter.

E. Clean Room Applications

The series 490 can be used for monitoring clean room crossflows. Proper HEPA air circulation assures that clean air is efficiently issued from an HEPA ceiling duct and contaminated air is expelled from the protected zone. The probe can be positioned at various points in the clean room in a variety of orientations, establishing major flow lines and investigating the differential pressure of various rooms.

The 490 can also be used to certify HEPA filters, in accordance with governmental standards, and to assure uniform laminar airflow through the filter. This is accomplished by setting meter sensitivity to low and taking readings repeatedly. For HEPA certification, readings should fall between 72 and 108 fpm.

SECTION 5

Specifications

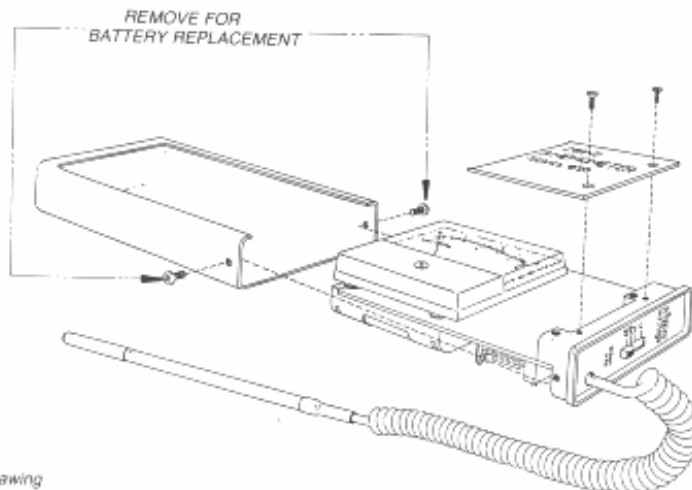

Figure 2
SERIES 490
Breakaway Drawing

If a return or suction opening is covered by a grill and it is necessary to compute the total flow into the opening, the correct procedure is to take a number of readings at the center of equal areas to determine the average velocity, as in the case of having no grill. The flow rate can be computed fairly accurately with the following equation:

- $Q = F A \bar{V}$, where
- Q = flow rate in standard cubic feet-per-minute
- F = the application factor (see following table)
- A = designated area in square feet, and
- \bar{V} = average velocity in standard feet-per-minute

<u>Grill type</u>	<u>Application Factors (F)</u>	<u>Designated areas</u>
No Grill	1.00	Full duct area
Square punched grill	0.88	Full (daylight) area
Bar grill	0.78	Core area
Steel strip grill	0.73	Core area

For applications requiring greater accuracy, it is suggested that a duct extension be used having a length of at least 10 percent of the largest dimension of the grill. (e.g. a grill having dimensions of 10 inches x 8 inches would require an extension of at least one inch, or 10 percent of the largest dimension). This duct extension is placed against the grill and the procedures for measuring an open grill are followed to compute flow rate. For greatest accuracy, a smoothly tapered flow nozzle should be placed over the supply grill. The velocity profile at the exit jet of such a nozzle will necessarily be very flat.

C. Velocities and Flow Rates in Small Ducts

The 490 can be used to take velocity measurement within a duct provided the duct diameter is less than 18 inches and the air velocity is fairly uniform. (For larger ducts refer to the Series 440 Portable Air Velocity Meters, featuring much longer probes.) Whenever possible, choose a measurement location at least 10 duct diameters downstream from the nearest elbow, tee, bend, valve or other flow obstruction. This optimizes the profile. The 490 probe can be semi-permanently mounted in the wall of the duct using a Kurz Probe Mounting Adapter. The adapter is easily installed by drilling a 1/4" hole into the duct and mounting the adapting plate with four sheet metal screws. (see Figure 1)

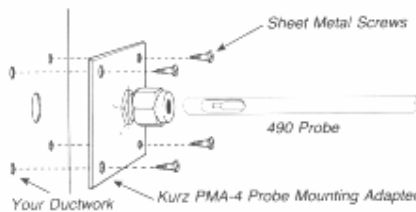

Figure 1 For mounting the 490 in sheet metal ducts, use the Kurz Probe Mounting Adapter part number PMA-4. This is a 2" x 2" .060" sheet metal plate with 4 corner mounting holes, and with a 1/4" compression fitting welded to the center of the plate. The 1/4" compression fitting is the ideal way to mount the 1/4" O.D. 490 probe. The user drills holes in his sheet metal ductwork using the PMA-4 as a guide, then installs it with 4 sheet metal screws. Then simply insert the 490 probe and tighten the fitting.

The total flow rate within the duct can be determined if the point velocity measurement is representative of the average velocity. This is generally not the case unless the velocity profile is extremely smooth or unless a multi-point traverse is conducted (a difficult task in small ducts).

Figure 3
SERIES 490
 Electrical Circuit Diagram

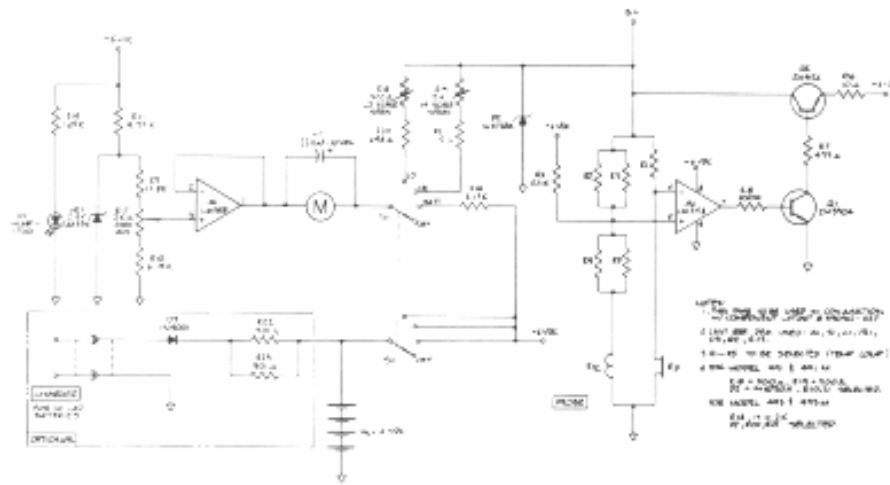
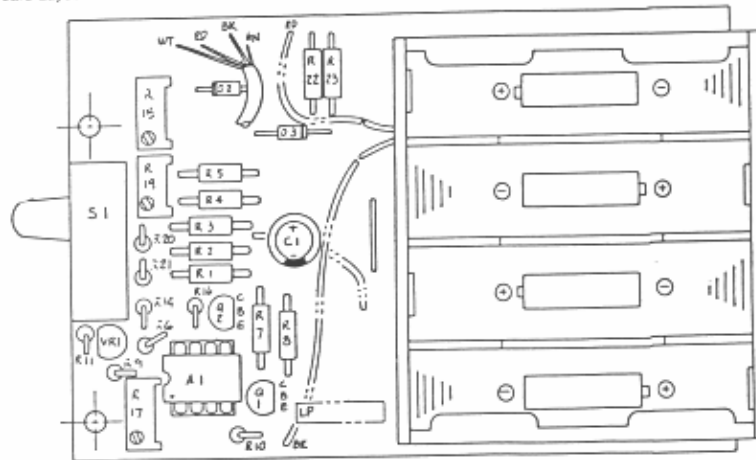

Figure 4
SERIES 490
 P.C. Board Layout



SECTION 6

Maintenance and Battery Replacement

The 490 operates with four (4) AA alkaline batteries. These batteries must be replaced when testing indicates they are worn. Check battery voltage by moving the slide-switch to the "BAT" position and observing the scale. If the needle is not above the scale symbol, the batteries must be replaced, or poor performance will result. Insufficient battery voltage will affect the accuracy of the system, and may cause a deflection at zero, with no velocity present.

To replace the batteries, simply remove the two screws at the top and bottom of the meter case. (Do NOT remove the screws on the base plate.) Slide the case away from the baseplate, exposing the battery compartments, and remove the four batteries while observing the polarity indications. Depress the spring-loaded batteries slightly with the head of a screwdriver to aid in reinstallation of the battery covers. Once the meter case is reassembled, the unit is ready for operation. (See Figure 2)

Those Mini Anemometers equipped with Kurz's optional Ni-Cad battery kit can be recharged for continuous operation. The kit includes a battery charger and a convenient jack mounted in the face of the 490 to accommodate the charger plug. Depleted Ni-Cad batteries merely require an overnight recharge of 16 hours to restore full service.

Although the large diameter of Kurz's low power sensors make them generally immune to particulate contamination, continued use in dirty environments may necessitate periodic cleaning of the sensor. This can be done by gently waving the probe back and forth in a bath of alcohol. This will remove most of the dust and grime and should restore the unit to normal operation. The sensor should be dry before resuming operation. (DO NOT touch the sensor coil with a brush or other object during the cleaning process.) Always protect the probe when not in use.

Recalibration should be performed annually under normal circumstances, depending on the accuracy of data needed and the amount of use. Prior to shipping for recalibration, contact Kurz's service department to obtain a return authorization number. This expedites the calibration/shipping process and will provide you with more timely service. Meters can be returned to:

KURZ INSTRUMENTS, INC.
2411 GARDEN ROAD
MONTEREY, CA 93940

When shipping, be sure to include user name, address and phone number.