

Kurz Instruments Inc.



Series 155 Mass Flow Computer Summary Guide DCN: 360204-6.81 Rev. B Covers KAS Version 6.81 Firmware

November 2007

ISO-9001

Kurz Instruments Inc.
2411 Garden Road
Monterey, CA 93940-5394
USA
Telephone (831) 646-5911 or 800-424-7356
FAX (831) 646-8901 or (831)-646-1033

www.kurz-instruments.com

Table of Contents

INTRODUCTION	4
OPERATION OF THE SERIES 155 MASS FLOW COMPUTER	5
Navigating the Menus	5
Display Mode	6
Program Mode	8
Functions Available in Program Mode	8
System Configuration:	8
Input Channel Linearizer:	8
METER Setup:	8
Output Setup:	9
Calibration:	9
Input Channel Filtering:	9
International/English unit system:	9
Channel Kickout:	9
Totalizer Reset:	9
Time and Date:	10
PID Control:	10
Alarms:	10
Pulsed Output:	10
Data Logging:	10
How To Calibrate The 4-20 mA Outputs	11
Ranging the 4-20 mA Output	12
Input Calibration	13
Channel Kickout	14
METER Correction Factors	14
Configuring CCF	15
Daily Zero-Span Drift Check	17
Daily Zero-Span setup adjustments for the supported 155 Flow Computers	17
Adjustment of Drift Check Zero and Span Values	18
Setup Verification METER	20
Alarm Verification	22
FLOW CALIBRATION	23
Field Calibration	23
TROUBLESHOOTING	24

INSTALLATION	27
Mounting	27
Power	27
Flow Element and Output Wiring	27
RETURN SHIPMENT	28
RMA (Return Material Authorization) Number	28
Cleaning of Material to be Returned	28
Shipping Material to be Returned	29
GLOSSARY	30
APPENDIX A	33
Product Brochure	33
APPENDIX B	34
Product Approvals	34
APPENDIX C	36
Field Wiring Diagrams	36
APPENDIX D	37
State Menu Diagrams	37

Introduction

The Series 155 Mass Flow Computer is designed to be used with any number of Kurz flow elements which are calibrated for:

- velocity as insertion elements or
- volumetric/mass flow on the in-line flow elements.

These flow elements include but are not limited to the Series, 410, 450, 452, K-BAR-16, K-BAR-24 insertion elements and the Series 500, 502, 510, 522-UHP, 532 in-line flow elements. The 155 provides power to the flow element, linearizes its data, provides local/remote display, averages, alarms and provides 4-20 mA scaled linear outputs. Additional information on the Series 155 specifications and features can be found in the product brochure in the next section.

The 155 is also used to post process the linearized signal from flow transmitters like the MFT series: the 454FT, 504FT, 534FT, K-BAR-2000 and the MFT B-Series: 454FTB, 504FTB, 534FTB and K-BAR-2000B.

This manual covers basic operation, configuration, navigation through the menus and has the full menu state diagram in the appendix. The Series 155 product brochure with dimensions, specifications and part numbers is included in Appendix A. Please see the flow element or transmitter manuals for more information on what the thermal anemometer measures and installation issues for accurate flow measurements.

Information in the 155 is broken down into a few key concepts;

Channel: A channel applies to one of the flow sensor inputs. These are assigned as A to V or up to 22 depending on which 155 unit you have. The sensor calibration curve or linearizer table is associated with its corresponding sensor/channel. The sensor's serial number will be programmed along with its calibration data to facilitate connecting the proper sensor to the proper channel.

Output: The analog output ports are known as 1 to 8 depending on which 155 unit you have. These can be 0-5 V or 4-20 mA but not both on the same output. You scale the Meter output (engineering units) to the analog scales in analog output area.

METER: A METER is the internal name given to flow processing section of the flow computer. A METER has at least one input channel assigned to it and typically 1 output assigned to it. The 155 Series can have up to 16 meters. The METER area is where you find ID

tags, duct area, specific gravity, velocity dependent correction factors, specification of the engineering flow units.

Operation Of The Series 155 Mass Flow Computer

The 155 has four states following boot up.

- *Executive State*, scrolls through the online help and date/time on the LCD while performing all flow calculations on a (2+ # channels) x 0.1 s loop time for the 4-20 mA outputs.
- *Display mode* where you can view all the *METERS*, flow, velocity, temperature etc.
- *Program mode* where you can configure the parameters of the flow computer. The most common operations are defined in this summary guide. Other operations can be figured out from the KAS Menu State diagram (340155-26 in Appendix D)
- *Boot up error screen*. At power on, or boot, if the CPU detects a checksum error in the configuration data, linearization data etc. which is stored in the battery backed up SRAM, it will indicate an error code. It will not proceed to the *Executive State* until the error is acknowledged by pressing the **C** key. If it can operate normally, it will, depending on the error. It may operate on default data, which will allow changes to be made to correct it but it will need operator intervention. See the troubleshooting section for more discussion on this subject.

So if the unit has power, it is doing its flow calculations according to the configuration stored in its SRAM. The SRAM is maintained by a lithium coin cell which generally last 5 to 10 years. This cell is soldered on the backside of the CPU board where the LCD and keypad are located.

Navigating the Menus

To operate the 155 control panel, you simply press the keypad navigation keys for that function or you can use the same keys in lower case via a remote RS-232 terminal. The remote terminal operation uses a straight through DB-9 connector from a PC serial port to the data terminal port on the Series 155.

Navigation Keys:

P is for *Program mode*. Parameter settings for the flow computer are viewed or changed in this area, also know as the configuration settings.

D is for *Display mode*. This area allows viewing of all the METER and sensor channels connected to those METERS.

C is for clear. This will clear the screen you are viewing and return to the main menu category you are in. If you are viewing menu categories for *Program mode* or *Display mode* it will exit to the *Executive state*.

E is for enter. This key is required to enter a menu category or to accept a new parameter.

^ is for selecting an item in the up direction also known as **Yes** selection.

v is for selecting an item in the down direction also known as the **No** selection.

H is for hold. This is used to freeze the screen or menu on the one displayed. The values will update but only this screen will be shown.

HH is for help. This will bring up the built in description of the above commands and our phone number.

Display Mode

The *Display mode* is the menu area accessed by the **D** key to view all METER data, flow rate, average velocity, mass rate, included channels and kickout status, flow area, and the included channel response.

To view the flow rate of a METER you simply press the **D** key then using the number pad or the **^v** keys to select the METER number (1 to 16) followed by **E** to accept this METER.

**DISPLAY NEXT ^v
METER #XX**

You can advance through the menus by pressing the **D** or **E** key. If you want to exit this and look at another METER you simply press the **C** key or clear then select the next METER number of interest. Next you will see the METER ID, time and date.

**ID: meterID
hh:mm mm/dd/yyyy**

You press the **D** key to advance to the flow rate screen. This is averaged data based on the time constant set under the Input Filter menu under program mode. The flow rate on an insertion flow meter is the average velocity times the correction factor at this average velocity times the METER area. This screen and sample screens apply to insertion velocity elements and in-line flow elements. For temperature, mass rate or sum METERS, please refer to the full menu state diagram in the appendix.

**FLOWRATE
41,045.4 SCFM**

Advancing past the flow rate screen we come to the METER totalization and elapsed time since the last Totallizer Reset. The totalization algorithm has about six digits of resolution and will totalize for about four years and be within 1% of the true value. The time resolution is to 0.1 minutes for the totalization.

SCF 234567
ET = 3489.1 MIN

The next screen you come to is the average velocity for the METER chosen. This is based on a straight average of all the input channels assigned to the METER times the correction factor at the raw velocity computed. Again, you can hold any one of these screens by pressing the **H** key. If you dwell on a screen for more than two minutes without pressing any keys on the front panel, it will revert to *Executive State*.

AVERAGE VELOCITY
6089.45 SFPM

The correction factor or calibration factor applied to the METER at the current raw average velocity is shown next. The correction factor is required to convert the point velocity measurements to the true average (see the calibration section for field calibration methods)

CALIBRATION
FACTOR 1.00

The METER flow area used to multiply the average velocity by is shown next. For metric METERS, this will be square meters.

FLOW AREA
3.567 SQ FT

Advancing with the **D** key past the flow area we come to the included input channel screen. For each input channel we see its letter. An input channel which has been kicked out will be indicated with a question mark (?). The example shown here has input channels A to J included with channel H kicked out.

AVG'D CHS ABCDEF
G?IJ

The last screen we come to in the Display area shows the raw, unfiltered flow rate or velocity for that input channel and its corresponding input voltage from a bridge board or flow element output. This voltage is generated from a current flowing from the bridge circuit or a 4-20 mA transmitter flowing through a current sensing resistor. The current sense resistors vary from 5 to 15 ohm for bridge boards and are typically 250 ohm for 4-20 mA inputs.

A = 5478.46 SFPM
INPUT = 1.896 V

A METER can be setup as temperature, mass rate or a sum METER which have not been shown here. Please refer to the state menu diagram (340155-26) in the appendix for the full menu layout.

Program Mode

The *Program mode* of the Series 155 is used to enter, change or view the parameters used to configure the Mass Flow Computer. A full account of what can be done with the 155 mass flow computer can be gleaned from the complete menu state diagram (340155-26) in the appendix. The following sections represent the most common issues users want to know about.

To enter program mode you press the **P** key followed by either the **user code** (123456) or the **tech code** (654321) and then the **E** key. The **user code** only allows you to setup the alarms, view PID operation (not discussed) and channel kick-outs. All other functions need the **tech code**. These codes may be changed but this must be arranged by a Kurz customer service person as it requires the Factory Access Code.

Functions Available in Program Mode

All of the programming menus and controls are shown on the State Menu Diagram (340155-26 in Appendix D) and navigation of this was described previously. This is an outline of what you can do in the program mode. Some of the more common issues are detailed in a subsequent section.

System Configuration:

The 155 flow computer software capacity is specified in this menu area. Depending on the model and features ordered will determine how many, input channels, METERS, outputs, alarms, PID channels, pulsed outputs, Logging and Standard Air Density are set for. This menu area requires the Kurz factory code.

Input Channel Linearizer:

The linearizer tables allow the 155 flow computer to do a LaGrange second order interpolation of the calibration data. Up to 15 points may be entered. For units with multiple temperature sets or Velocity Temperature Mapping (VTM) you can enter up to seven points per temperature, with three temperatures maximum. You also specify the Reference METER which has the temperature signal for this second order correction with each input channel.

METER Setup:

ID, Area, Flow Units, Specific Gravity (if mass flow engineering units)
Included Channels, Correction Factor CCF/VCF.

Output Setup:

The output channel assignment and scale for a METER are programmable. See a subsequent section with a detailed description on how this is done.

Calibration:

Output and Input circuits must be matched to real voltage and currents which are done with these menus. See the subsequent section for a detailed description of how this is done for the 0-5 V or 4-20 mA output.

The input calibration uses various methods of substituting a zero or span voltage to the input channels of each 155 unit. See the field wiring diagram for identification of the switches used for this purpose. Generally, there is a calibrate/operate switch. When in calibration there is another switch which selects zero or span. The span voltage must be measured with a 4 ½ digit multimeter with 0.1% basic DC accuracy to calibrate the inputs. As input voltages are raised to about the 4th power to convert the raw input to a flow or velocity, this process is critical and must be performed by a competent operator with an accurate voltage standard.

Input Channel Filtering:

Flow noise reduction is achieved by choosing a time constant (τ , τ), like that which applies to an electrical circuit with a resistor (R) and capacitor (C) making a low pass filter, $\tau = RC$. With a step change on the input, after one time constant the output will reach 63% of its final value. The settling time is about five time constants to reach the final output within 1%.

International/English unit system:

You can select which units the system is operation with, English or metric but this requires a factory access code to change so the unit must be ordered this way.

Channel Kickout:

This specifies when a defective flow element will be removed from the flow calculations. See the subsequent section on this.

Totalizer Reset:

Each METER has its own flow total and elapsed time. They can be reset to zero in this menu. The internal variables are limited to about seven digits and will properly accumulate the total for about four years (~1% mistrack). So if you need to use this function, its best to clear it every so many years.

Time and Date:

There is a year 2000 compliant real time clock and calendar, which annotates the display and logged output. The clock has one-minute resolution.

PID Control:

The Series 155 can operate the Kurz 730 electric valves which take a +/- 15 VDC drive signal to wind open or close the valve. This software will regulate the flow based on a fixed internal set point or an external set point. This software can also command a 4-20 mA valve or motor speed control directly but there is an external integrator board required to convert the +/- 15 VDC pulsed motor drive to a continuous current. Each PID channel uses two alarm channels.

Alarms:

There are up to eight alarms available on the 155 hardware depending on the model. These can be flow/temperature events or sensor kickout. Once assigned, the alarm can be On/Off, Normally Open or Closed, HI, Low, HI/Low based on a set point. You associate the alarm channel with a METER number. The alarms are self-clearing not requiring a reset, however, the display may hold the alarm until you press clear (**C** key). There are no dead-band or hysteresis settings for the alarms.

Pulsed Output:

You may assign one or more alarm output channels (8 max.) to be pulsed total outputs. When X units of flow has been totalized, a 50 ms pulse (active low) is generated (TTL open collector (30 V, 20 mA) with a small 5 V pull up resistor on it). This output method is designed to simulate the output of a mechanical totalizing meter. As the pulse rate is limited to the output update rate (0.3 to 2.4 s), it can not be used to measure flow rate as a variable frequency. The field wiring diagrams for these pulsed output versions are not included in this summary guide. They are 340155-57 for the 155-C-2/E-2/RM2, 340155-58 for the 155-Jr and 340155-59 for the 155Jr-DC.

Data Logging:

There are three ways you can extract digital data from the Series 155:

1. Log the LCD screen data with a program like "Hyper Terminal" which comes with Windows. See Windows documentation on how to setup this up and use it. You place the LCD display screen of interest on hold then capture the text to a file. It will provide data about every two seconds but there is no time stamp.
2. Issue an "x" command to the terminal port which provides a summary of the METERS with a time/date stamp each time the command is issued. This works best when the terminal echo is turned off (toggles

with the “+” command). This can be slightly parsed to be readable by a spreadsheet program (like Excel) or MathCad etc. which can make trend plots or do other subsequent data processing. You can use the Kurz PC data logging program (451022) which will do this parsing and has a programmable polling rate. It will also average samples.

3. The data logging port which is designed for a printer can also provide a long winded version of the “x” command. This log or “l” command does not come back at the data terminal port but the data logging port of the Series 155. You can press the **L** key on the front panel, use an internal timer or a remote terminal to issue this command but the data always goes to the second serial port or the data logging port. The internal timer for issuing a log is known as the “log interval” which can be set in one minute values up to 999 minutes.

How To Calibrate The 4-20 mA Outputs

The 4-20 mA calibration ensures that when the flow computer thinks it is outputting 6.23 mA that it is actually doing this. The 4-20 mA outputs are in cascade with a 0-5 V output of the Series 155. You can have either the 0-5 V calibrated or the 4-20 mA but not both at the same time. The menus under program mode cover calibration of the 0 to 5 V output, which correspond to 4 to 20 mA respectively.

Enter *Program mode* by pressing **P** followed by the **tech code** then enter **E**. Press **P** until you reach the menu category *CALIBRATE* followed by pressing **E**. Next you press **P** until you see the screen for *OUTPUT CAL.* and press **E**. Next you see the screen:

SET 'ZERO' VOLTS
CH 1 = 0.0000 V

Using an external current meter, 4 ½ digit resolution with 0.1% basic DC accuracy, you monitor the 4-20 mA signal which should have jumped to about 4 mA. Now you press the **^v** keys to increment or decrement the value observed on your external meter until it is as close to 4.000 mA as you can set then press **E**. The next screen will be:

SET 'SPAN' VOLTS
CH 1 = 5.0000 V

Using your external current meter you press the **^v** keys to increment or decrement the value observed on your external meter until it is as close to 20.000 mA as you can set then press **E**. Congratulations you are done with this **METER!** If you do not need to proceed with the other output channels, press **C** several times to leave *Program mode* until you are back to the top menus which scroll.

The next screen will be for CH 2 and will repeat the above settings for up to eight output channels depending on which 155 unit you have.

Ranging the 4-20 mA Output

To change the scale of the output range you must enter *Program mode* to specify the zero value for 4 mA, span for 20 mA and which analog output channel is assigned to the METER you want to transmit. The units available for the METER output depend on if the METER is flow rate, mass or temperature and the unit system, English or metric (the unit-system is a Factory program option only).

Enter Program mode by pressing **P** followed by the **tech. code** and **E**. Use the **P** key to find the menu category SET ANALOG OUTPUT then press **E**. The next screen:

**PRESS ENTER FOR
ANALOG OUT 1**

can be changed to Output 1 - 8 but using the **^v** keys or the number on the keypad followed by **E** to select that output channel. The next screen:

**ANALOG OUT 1
ENTER METER # 1**

is used to select which METER, 1 to 16 that is assigned to output channel 1. You use the **^v** keys or type the number on the keypad to select the METER number followed by **E**. The next screen:

**OUT #1 NEXT TYPE
^v FLOW RATE**

can be FLOW RATE or AVE VELOCITY for an insertion flow meter. If flow rate is selected, the specific flow units which show up depend on the METER type, volumetric (SCFM, SCFH, SCMM, SLPM) or mass rate (PPM, KGM) selected under the *SET METER DATA* menu category. The following screens select the zero and span values.

LO 0.0000000 SCFM

Where you can use the **^v** keys or type the value on the keypad followed by **E** to accept the value. The next screen shows:

**LO 0.000000 SCFM
AT 0.0000 V**

You enter the voltage corresponding to the low output value and press **E** to accept. Leaving this at 0 V means 4 mA. The next screen is for the span which looks like:

HI XXXXX SCFM

You enter the value for span with the keypad or **^v** keys followed by **E** to accept. The next screen shows you the voltage of the span value, 5.00 V corresponds to 20 mA which you have previously calibrated.

**HI XXXXX SCFM
AT 5.000V**

You can change the value with the keypad or **^v** keys followed by **E** to accept the changes. The next screen is for the next analog output which you can setup and repeat the above sequence or change the output number with the **^v** keys or keypad followed by **E** to accept the output channel number.

**PRESS ENTER FOR
ANALOG OUT 2**

Once you have set the output channel ranges you press **C** several times to move backup up through the menus and exit *Program mode*.

Input Calibration

Please refer to the appropriate field wiring diagram in the Appendix for the following procedure. Each of the 155 models has a run or operate/calibrate switch or shunt defined on this drawing. (see the Installation section for a table of the drawings for each model)

Once in calibrate, another switch or shunt determines what voltage will be applied to the inputs. This voltage should be monitored with a precision multimeter with 4 ½ digit scale and 0.1% basic accuracy. Placing the volt meter ground at TPx and its positive lead on TPy you can read the exact voltage applied to the inputs.

Next, place the 155 in *Program Mode* and navigate to the Calibration menu

**PRESS ENTER TO
CALIBRATE**

You press the **E** key and you should see the next menu for input calibration, if not press the **^v** key until you do:

**PRESS ENTER FOR
INPUT CAL.**

Again you press the **E** key and you will now see this screen for the first input channel:

**SET 'ZERO' VOLTS
CH A =0.0000 V**

You must have the input switch in the ZERO position and the multimeter reading 0.000 V. If they all agree you press **E** to move to the span setting. If the readings are not near zero, say 0.0056 then enter this number on the keypad followed by the **E** key.

**SET 'SPAN' VOLTS
CH A =5.0000 V**

Which will read about 5 V when the input switch is in the SPAN position. Again you type in the actual voltage reading of the volt meter followed by the **E** key. You will now see the same menu screen for channel B:

**SET 'ZERO' VOLTS
CH B =0.0000 V**

Now you repeat the process you did for channel A. This is done for all active input channels.

When you are done, you press the **C** key a few times to exit *Program mode* and place the operate/calibrate switch/shut back into the operate position.

Channel Kickout

A channel kick-out (due to malfunction) is based on a % change in this linearized range, not the output range. Typically this is set to -1 % to 110 % of the calibrated velocity range for an insertion element or flow range of an in-line flow element. This function must be on for all channels or off for all channels. The only way to trim the kickout values between channels is by editing the linearizer data to cover more or less range.

This function is used to remove a defective sensor or disconnected sensor from a METER average calculation. On a four point K-BAR system, the readings would be 25% low if one of the sensors went out and it was not removed from the average. Alternately, the sensor can fail reading high velocity and this too would be removed by having an upper limit on the range (110% for example).

METER Correction Factors

There are two methods available in the 155 flow computer to apply field derived correction factors. The first is known as Variable Correction Factor (VCF) and the other is Configuration Correction Factor (CCF).

The VCF method allows up to seven correction factors at different average velocities. At each velocity of interest, you enter a number, which will multiply the data to achieve the correct flow rate. While the Series 155 is often configured for flow rate or mass rate, the VCF data area entered using the average velocity corresponding to that flow/mass rate. This method is easy to setup but does not have the automatic recovery that the CCF offers for consistent flow profiles. Profiles that vary a lot with the operating state of the process are best served with lots of sensors. The loss of one or two sensors will not be noticed as much if you have a dense multipoint array.

The CCF method allows up to four correction factors at different average velocities but it acts on each sensor channel of a multipoint array. This method will recompute the net correction factor for systems with consistent flow profiles if a sensor is disconnected or Kicked-out to read the same average velocity. Note you must have the channel Kickout turned on for this to work. Since each sensor is acted on separately with its own correction factor, we must collect data on every sensor and the true reading or reference rate. To collect all this data on each sensor, the 155 has a log command know as "L". There is a key for this on the front panel. This data is sent to the second serial port, not the terminal RS-232 port.

During your field calibration you connect a computer to the log port and let the internal log internal timer send data to a printer or computer capturing this text which will be sent as often as each minute. The log interval timer data is entered as hhh:mm where the hhh is for hours and mm is minutes. Do not leave this timer set for minute intervals when not using it as the extra CPU time spent doing these extensive logs can cause the analog output or 4-20 mA signal to glitch in error. It is best to set the log interval to 999:00 when it is not needed which reduces the chance of a glitch to very low levels.

Depending on the number of correction factors used in the meter channel, will determine velocity dependent function for the correction factor. With one point we have a simple bias change at all velocities. With two points we have a single sloping line correction. With three points we have two lines, with 4 or more points there are two lines with a curving function over the center velocity points. These functions are shown with five examples in the K-BAR-2000B user's manual, 360211, under the field calibration section.

Configuring CCF

To setup the CCF, you enter *Program Mode* and advance to the Set Meter Data menu then press **P** until you reach the following screen:

CF TYPE ^=CCF V=VCF

You chose CCF by pressing the **^** key followed by the **E** key. If you are not already in the CCF mode you will see a temporary screen which says "NEW VALUE ACCEPTED". You will then see the screen for a bias correction factor (BCF), which is a constant that is flow rate independent. Keep the BCF at its default 1.00 value:

BCF=
1

Press the **P** key to advance past the BCF screen to the next screen:

ENTER # OF RM
DATA SETS 3

Here you enter the number of flow rate data sets you have collected data on. The RM refers the number of Reference Method data sets or flow rates you used. You might have used 100%, 75% and 50% of full scale in which case you would enter a **3** followed by the **E** key. Next you will see a screen to prompt you that data set 1 will be entered. You can use the **^v** keys to chose another data set if needed. You must start at the lowest flow rates first (50% for this example) and go up.

ENTER RM DATA
SET 1

Press the **P** or **E** key to move on to the next screen where you enter the average velocity computed from your traverse or other Reference Method that can compute the duct average velocity.

Vrm1
xxxx.xx SMPS

The Vrm1 is the reference method average velocity for data set 1. You enter the average velocity then press the **E** key. Next you see the screens for the individual channel velocities measured with the log at the same time you took the reference flow data.

Vds1 CH B
xxxx.xx SMPS

This is the observed velocity for the first included channel of that METER being calibrated. You repeat this process for all the included channels of the multipoint sensor element METERS.

After you enter the data for all channels, you will see the computed correction factor when all channels are active.

C.F. #1 = 0.980
AT 48.78 SMPS

You can now press the **P** or **E** keys to move to the next data set (if any) and repeat the channel data entry process listed above. Remember that you must enter the data from the lowest velocities up starting at data set 1.

Daily Zero-Span Drift Check

The Series 155 have been designed to comply with the EPA (Environmental Protection Agency) regulations on large energy users for a daily zero-span drift check of the CEMS (Continuous Emissions Monitoring Systems). This is simply a circuit which substitutes a sensor input signal to the flow computer which is less than 25% full scale (zero) and a different signal which is greater than 75% full scale (span). During this check, the flow computer output is compared to a previously certified response to check its tracking. This feature is not supported on the two smallest flow computers, the 155Jr or 155Jr-DC.

Note: The **MFT B-Series** (454FTB, 504FTB, 534FTB & K-BAR-2000B) have their own zero-mid-span drift check signals, closer to where the sensors are measured, which should be used instead of what is built-in to the 155 flow computer. Please skip this section and refer the user's manual on these products for Zero-Mid-Span EPA compliance support.

The flow system must be field calibrated and reading the absolute value of interest before setting up the Zero-Span drift check. Otherwise, the % output values you set might shift.

The field wiring diagrams for the flow computers should be referenced to locate the variable resistors, switches, jumpers and terminals that will be referenced. The following table should be used to locate these components depending on which 155 unit you have.

Daily Zero-Span setup adjustments for the supported 155 Flow Computers

	155A/B/B-RM	155C-2/E-2/RM2
Zero adjustment	R47	R110
Span adjustment	R44	R108
Local Zero switch	NA	SW102, hold at Zero
Local Span switch	NA	SW102, hold at Span
External Zero Drift Check Enable	TB22-1 and 2	TB401-9 and 10
External Span Drift Check Enable	TB21-1 and 2	TB401-11 and 12
Verification Channel adjustment	R57	R103
Verification Channel Selection	J8 is Channels A, B and C; J9 is Channels D, E and F. One shut is used	J102, pins 1 to 22 are Channels A to V. One shut is used horizontally

	vertically in the position for the verify channel.	for the verify channel.
Verification Alarm Contacts	User defined in <i>Program mode</i> to match the verification channel METER.	

Implementation of this feature requires the following steps:

1. Adjustment of zero and span drift check flow values.
2. Setup of Verification METER.
3. Alarm verification.

The flow value in SCFM (or SCMM) for a full scale, 5 VDC or 20 mA, output must be obtained so that the calculations required for set-up of the verification METER can be obtained.

The following percentages of full scale flow value need to be calculated:

10% _____
 15% _____
 85% _____
 90% _____

The example below illustrates these steps for an instrument where the full scale flow output at 5 VDC = 3000 SCFM:

10% 300 SCFM

 15% 450 SCFM

 85% 2550 SCFM

 90% 2700 SCFM

Adjustment of Drift Check Zero and Span Values

1. Remove the cover panel of the Model 155C-2/E-2/E-RM2 Mass Flow meter Computer/Transmitter.
2. Adjust and record "zero" flow rate value.
 - 2.1 From the Executive Mode, press **D** to enter the Display Mode.
 - 2.2 Press **D** until you see the METER flow rate indication on the front panel LCD.
 - 2.3 Press **H** to hold the display.

- 2.4 Hold internal zero/span switch (or external contact) on the Series 155 motherboard in the ZERO position and adjust the Zero variable resistor until the front panel display indicates 10% of full scale span for your system.
 - 2.5 Record flow rate indication and release the switch (or external contact).
 - 2.6 Press **C** to clear the hold function.
 - 2.7 Press **D** until you see the Input Voltage display.
 - 2.8 Hold internal zero/span switch (or external contact) on the Series 155 motherboard in the ZERO position and record input voltage.
 - 2.9 Verify that the 4-20 mA output reads 10% of flow rate range and record value.
3. Adjust and record "span" flow rate value.
 - 3.1 Press **D** until you see the flow rate displayed as in step 2.2.
 - 3.2 Press **H** to hold the display.
 - 3.3 Hold internal zero/span switch (or external contact) on the Series 155 motherboard in the SPAN position and adjust the Span variable resistor until the front panel display indicates 90% of full scale value for your system.
 - 3.4 Record the flow rate indication and release switch or external contact.
 - 3.5 Press **C** to clear the hold function.
 - 3.6 Press **D** until you see the Input Voltage display.
 - 3.7 Hold internal zero/span switch (or external contact) on the Series 155 motherboard in the SPAN position and record input voltage.
 - 3.8 Verify that the 4-20 mA output reads 90% of flow rate range and record value.
4. Verify external control function (155C-2/E-2/RM2 only)
 - 4.1 Short the terminals labeled EXT. ZERO DRIFT CHECK ENABLE on the front panel together (terminals 9 and 10 of TB401).
 - 4.2 Verify that the Series 155 flow rate indications and 4-20 mA values match the recorded data in steps 2.4 and 2.9.
 - 4.3 Remove short from terminals 9 and 10 of TB401.
 - 4.4 Short the terminals labeled EXT. SPAN DRIFT CHECK ENABLE on the front panel together (terminals 11 and 12 of TB401).
 - 4.5 Verify that the Series 155 flow rate indications and 4-20 mA values match recorded data in steps 3.3 and 3.8.

- 4.6 Remove short from terminals 11 and 12 of TB401.

Setup Verification METER

1. Set METER Definitions

- 1.1 Enter the Program Mode
- 1.2 Press the **up (YES)** or **down (NO)** arrow until the message "PRESS ENTER TO SET METER DATA" is displayed on the front panel LCD.
- 1.3 Press **E**, then press the **up (YES)** or **down (NO)** button until the LCD indicates the first unused METER number, then press **E**.
- 1.4 Using the 20 button keypad, enter the desired METER ID, such as "ZERO/SPAN".
- 1.5 Press **E** to accept the METER type as "INSERTION FLOW".
- 1.6 Press the **up (YES)** or **down (NO)** arrow until the message "DISPLAY NEXT ^v FLOW IS SCFM" (or SCMM), appears on the front panel LCD.
- 1.7 Press **E** to accept "FLOW IS SCFM" (or SCMM).
- 1.8 The next messages will ask you which channels to include. Press the **down (NO)** arrow and **E** to bypass the channels already used by the system. Press the **up (YES)** arrow and **E** to enter the first unused input channel (A, B, C, etc.). Press the **down (NO)** arrow and **E** for the remaining unused channels.
- 1.9 Using the 20-button keypad, enter the flow area of the duct in square feet.
- 1.10 Since correction factors are not required for this feature, press **C** until you see the message "PRESS ENTER TO SET METER X" where "X" is the next METER #.
- 1.11 Place a jumper on the appropriate contacts for the verify channel selected in step 1.8.

2. Define Linearization Points.

- 2.1 Press the **up (YES)** or **down (NO)** arrow until the following message appears on the front panel LCD. "PRESS ENTER TO SET LINEARIZERS"
- 2.2 Press the **up (YES)** or **down (NO)** arrow until the following message appears on the front panel LCD. "PRESS ENTER TO LINEARIZE CHANNEL X", where "X" is the channel selected for the zero/span drift check feature. Press **E** in response to the prompt.

- 2.3 Enter ID number of the zero/span METER as defined in step 1.4 of "SETUP VERIFICATION METER".
- 2.4 Press **up (YES)** or **down (NO)** arrow until message on front panel LCD indicates SCFM or SCMM units as selected in step 1.7 of "SETUP VERIFICATION METER", and press **E** to accept.
- 2.5 Press the buttons **2** and then **E**, in response to message "ENTER NUMBER OF CH (X) DATA POINTS XX".
- 2.6 For point 1, enter the voltage and flow units as noted in steps 2.5 and 2.8 of "ADJUSTMENT OF ZERO AND SPAN VALUES" for 10% of full-scale span.
- 2.7 For point 2, enter the voltage and flow units as noted in steps 3.4 and 3.7 of "ADJUSTMENT OF ZERO AND SPAN VALUES" for 90% of full-scale span.
- 2.8 Press **C** to return to main programming menu.

3. Designate Alarm Trip Points.

- 3.1 Press the **up (YES)** or **down (NO)** arrow until the message "PRESS ENTER TO SET ALARMS" appears on the front panel LCD, then press **E**.
- 3.2 Press **E** to access alarm #1 data.
- 3.3 Press **E** to enter alarm data for METER #1.
- 3.4 Press the **up (YES)** or **down (NO)** arrow until the message "ALARM 1 IS ON" appears on the front panel LCD, then press **E**.
- 3.5 Press the **up (YES)** or **down (NO)** arrow to select either N.O. (normally open) or N.C. (normally closed) contacts, as required by your system, are displayed then press **E**.
- 3.6 Press the **up (YES)** or **down (NO)** arrow to select the type of alarm (usually flow rate or velocity for this feature), then press **E**.
- 3.7 Press **1** to select low alarm, then press **E**.
- 3.8 Enter a value equal to 15% of full-scale span.
- 3.9 Press **E** to access alarm #2 data.
- 3.10 Press **E** to enter alarm data for METER #2.
- 3.11 Press the **up (YES)** or **down (NO)** arrow until the message "ALARM 2 IS ON" appears on the front panel LCD, then press **E**.
- 3.12 Press the **up (YES)** or **down (NO)** arrow to select either N.O. (normally open) or N.C. (normally closed) contacts, as required by your system, are displayed then press **E**.

- 3.13 Press the **up (YES)** or **down (NO)** arrow to select the type of alarm (usually flow rate or velocity for this feature), then press **E**.
- 3.14 Press **2** to select high alarm, then press **E**.
- 3.15 Enter a value = to 85% of full-scale span.
- 3.16 Press **C** until the title screen of the Executive Menu appears.

Notes on the Zero and Span control switches: (155C-2/E-2/RM2 only)

The zero-span control functions at TB401 only work if SW101 the “auto zero-span switch” is off.

The manual zero/span switch SW102 is independent of the position of SW101 the “auto zero-span switch.”

Alarm Verification

To verify the zero-span reference input (Verification Channel):

1. Select the zero-span METER and press **D** until you see the average flow indicated on the front panel display.
2. Adjust the variable resistor for the verification channel until the display reads approximately 50% of full-scale span.
3. To verify operation of the zero-span METER low alarm, hold the zero-span switch (or external contact) in the ZERO position. You should hear the alarm click and see the low alarm message on the front panel display.
4. To verify operation of the zero-span METER high alarm, hold the zero-span switch (or external contact) in the SPAN position. You should hear the alarm click and see the high alarm message on the front panel display.
5. Release switch to its center position or external contact. Verify that the alarms are reset and that the front panel display indicates the same value as step 2

Flow Calibration

The basic flow element calibration is done at the Factory but can be redone at any flow calibration lab. This data is standard velocity for insertion flow elements and standard volumetric flow or mass flow for in-line flow elements.

The 155 flow computer takes the current sense voltage (CSV) from a flow element's current across a 5 ohm resistor and converts this to an engineering unit flow, velocity, volumetric or mass rate. You simply enter this data into the linearizer section of the input channel for the flow element of interest as described in the programming section of this summary guide.

The main point with flow calibration and the 155 is performing a field calibration of an insertion velocity probe like the 452, 454FT, or the multi-point versions the K-BAR-24 and K-BAR-2000. The field calibration is required to account for site specific velocity profile issues and any residual mistracking from temperature or pressures which are different from the initial flow element calibration.

Field Calibration

Field calibration process permits a system to not only have a repeatable reading but absolute accuracy. Two field calibration procedures used at Kurz are:

Velocity Traverse and
Tracer Gas Dilution

The traverse is a classic method and has been documented by many standards organizations. This is defined in detail under Kurz procedure CAL-016 which covers traverses with both a Pitot tube and 2440 portable anemometer.

The tracer gas method is not as common but has many advantages. The main advantage points for the tracer method are the following:

- Independent of flow measurement technology to thermal or differential pressure,
- Insensitive to flow profiles,
- Insensitive to process pressure and temperature,
- Insensitive to many process fluid mixtures or variations in such.

The only down side for the tracer method is the special equipment needed to perform it. You can find more on the tracer gas method at our website under Technical Paper 364011.

A Kurz thermal anemometer system will provide a repeatable reading if properly installed for the specific application without the field calibration. If accuracy is needed, then the field calibration is required.

Troubleshooting

The main point here is to understand that a flow system using the Series 155 is made up of two parts, the flow elements and the flow computer. The flow element serial numbers must be matched to the 155 channels which have been set up for this purpose. It is important to isolate if the problem is related to the flow element or the flow computer. Information on both is provided here.

The following chart shows some of the most common issues and some proposed corrective actions.

TROUBLESHOOTING CHART	
Symptom	Possible Reasons
No 4-20 mA signal	<ul style="list-style-type: none"> •Loss of power to the flow computer. •Reversed polarity on 24 V power or 4-20 mA leads. •Self powered 4-20 mA units may have no power from the user's supply. •Open circuit in wiring. •4-20 mA jumpers not properly configured. See field wiring diagrams. •Damaged Electronics.
Output Signal "motor boating"	<ul style="list-style-type: none"> •Sensor has too much leakage current, corrosion or water damage. •Defective Bridge Board.
4-20 mA does not change with flow	<ul style="list-style-type: none"> •Are you connected to the proper output channel? •What is your programmed scale for the output, is it too large? •Defective Sensor, Bridge or Electronics. •Is the sensor cover removed?
No reading from sensor or ? on display for that channel	<ul style="list-style-type: none"> •Wire to sensor is open circuit or reverse polarity. •Check the input voltage across the load resistors, normal is 0.8 to 3.0 Volts. •All input channels have over current protection (PTC) which will reset if the load is removed for about 1 minute.
Unit does not read zero at zero flow	<ul style="list-style-type: none"> •The gas type or pressure may be different than when calibrated. •Defective electronics, Bridge or Sensor.
Unit saturates before reaching full scale.	<ul style="list-style-type: none"> •User selected output range is too low and 4-20 mA is clipping. •Unit calibrated for a lower flow rate at the Factory. •Unit calibrated for the wrong gas. •Defective bridge board or electronics.

<p>Calibration is too low.</p>	<ul style="list-style-type: none"> •Is the sensor orientated to the flow correctly? •Was the unit calibrated for the gas type in use? •Has the unit been set up for the duct's velocity profile? •Is there a temperature profile near the sensor? (e.g. hot duct center, cold outside) •Dirt will generally cause the reading to fall off from proper calibration. •Is the 4-20 mA output calibrated? •Is the operation temperature several hundred degrees C higher than calibrated at for higher flow rates? •Is the sensor connected to the proper input channel with the correct linearization data.
<p>Calibration is too high.</p>	<ul style="list-style-type: none"> •Have sensor blockage & flow profile effects been accounted for? This is a significant factor in ducts measuring less than 1 ft². •Is the sensor orientated to the flow correctly? •Was the unit calibrated for the gas type in use? •Is there a temperature profile near the sensor? (e.g. hot duct center, cold outside) •Is there condensation on the sensor? •Is there pulsating flow noise ? (e.g. from a pump inlet or exhaust) •Is the 4-20 mA calibrated? •Is the operation temperature several hundred degrees C higher than calibrated at for lower flow rates? •Is the sensor connected to the proper input channel with the correct linearization data.
<p>Calibration does not track with temperature.</p>	<ul style="list-style-type: none"> •Measurement is not actual velocity. Unit measures (density x velocity) or mass-rate per unit-area. (See Appendix A of the flow element manual information on converting to actual velocity). •Should you have used the VTM calibration method? • Is there a temperature profile near the sensor? (e.g. hot duct center, cold outside) •If you think it still is not tracking it may be a defective sensor or bridge board. •Is the sensor connected to the proper input channel with the correct linearization data.
<p>4-20 mA output is "noisy".</p>	<ul style="list-style-type: none"> •Missing ground? •Poor electrical contact. Make sure all electrical connections are clean and tight.
<p>"Cross talk" between Isolated 4-20 mA outputs.</p>	<ul style="list-style-type: none"> •"Isolated" 4-20 mA outputs may be tied to unnecessary grounds or the outputs are jumpered in the self-powered instead of the loop-powered 4-20 mA output configuration causing them to be nonisolated.
<p>Unit will not boot-up correctly.</p>	<ul style="list-style-type: none"> •Battery for SRAM has gone dead giving the ERROR 01234 •CPU is defective.

Display is blank	<ul style="list-style-type: none">▪ No power to the unit. See: no 4-20 mA signal.▪ Loose connectors between LCD/CPU board and the motherboard.▪ Defective electronics.
No RS-232 or RS-485 signal	<ul style="list-style-type: none">▪ Check the Jumpers on the motherboard for the proper RS-232/RS-485 position. Only one of the two signals can be used at a time.▪ Check pin-out of RS-232. Straight through DE-9 to DE-9 female to a laptop is recommended.▪ Check polarity of RS-485 wiring and pin-out.

Installation

The major points when installing a 155 flow computer are wiring up its sensors, outputs, power and mounting it. You need to find the following information:

- Field wiring diagrams (Appendix C) provide an overview of the wiring and
- each unit has a setup sheet shipped in its cabinet showing which sensor serial number has been assigned to what input channel as Factory programmed..

Mounting

The Series 155 have a NEMA4 design allowing them to be mounted indoors or outdoors. As long as the ambient temperatures are between –25 and +60 degree C the unit will work fine. All units have a four leg mounting scheme. The user should mount the unit vertically to support viewing of the LCD display at normal viewing angle. Separate conduit connections are provided for the power, inputs from flow elements and outputs.

Power

The 155 Jr/A/B units have transformer power supplies requiring either 115/230 VAC +/- 10%, 50/60 Hz 1 phase power. You select the 115 VAC or 230 VAC power connections via soldered jumper connections. Fusing is sized for either voltage including lighting surges. See the field wiring diagram for the fuse rating.

The 155-C2/E2/RM2 units have auto selecting switching power supplies and can accept any input from 85 to 260 VAC, 50 to 60 VAC, 1 phase power. The C2 uses a 250 VA power rating and the E2/RM2 use a 500 VA rating power connection.

Flow Element and Output Wiring

The flow element wiring, 4-20 mA inputs/outputs, alarms are defined on the field wiring diagrams. All field wiring must be in conduits and grounded or use shielded cable and have water seals at all electronics to prevent damage.

The field wiring diagrams for each model are as indicated in this table:

Document #	Description
340155-29	155Jr field wiring diagram
340155-44	155A field wiring diagram
340155-45	155B field wiring diagram
340155-50	155Jr-DC field wiring diagram
340155-55	155C-2/E-2/RM2 field wiring diagram
340155-57	155C-2/E-2/RM2 field wiring diagram with pulsed totalizer output

Return Shipment

RMA (Return Material Authorization) Number

If you believe your unit is not working properly, contact the Kurz Customer Service Department at: (831) 646-5911 or send E-mail to service@kurz-instruments.com. Please have the following information ready to give to the Kurz Customer Service Representative :

- Defective unit's model number and serial number,
- Detailed description of application and type of environment unit is being used in,
- Detailed description of perceived problem,
- Type of gas, Flow range, and standard conditions unit is to be recalibrated at,
- Any special QA requirements (nuclear or military application, oxygen service, special calibration or certification etc),
- Technical contact's name and phone number,
- Billing contact's name and phone number,
- Complete shipping address,
- Complete billing address.

You will then be issued an RMA number. **Kurz personnel will refuse to accept return material shipments if an RMA number is not visible on the outside surface of the shipping container.**

Cleaning of Material to be Returned

Thoroughly clean all material to be returned to Kurz. Because we serve a diverse customer base, there is a risk of receiving contaminated returned material from our customers. **When uncleaned material is received at Kurz, the customer will be contacted to arrange at their expense for the material to be picked up from Kurz and cleaned before Kurz personnel handle the equipment.**

Shipping Material to be Returned

Securely package cleaned material **(When uncleaned material is received at Kurz, the customer will be contacted to arrange at their expense for the material to be picked up from Kurz and cleaned before Kurz personnel handle the equipment)** along with a packing slip referencing the RMA number, model number and serial number in a sturdy container with the return address and RMA number clearly marked on the outside surface of the container. **Kurz personnel will refuse to accept return material shipments if an RMA number is not visible on the outside surface of the shipping container.**

Ship pre-paid to the following address:

KURZ INSTRUMENTS INC
CUSTOMER SERVICE DEPT
2411 GARDEN RD
MONTEREY CA 93940-5394
USA

Glossary

CORRECTION FACTOR: For insertion flow transmitters this is a number typically between 0.7 and 1.0 needed to convert a point velocity reading to the true duct average. This number is velocity or flow rate dependent. It can also be used to trim an in-line flow transmitter but the numbers are much closer to unity since the velocity profile information is built into the calibration.

DEGC: Degrees Celsius.

DEGF: Degrees Fahrenheit.

DISPLAY MODE: The set of display menus for viewing the METER readings.

EXECUTIVE MODE: This is the menu-state the flow meter starts in. You branch to Display Mode, Program Mode or can view the METER summaries from their scroll.

KGH: KiloGrams-per-Hour

LCD: Liquid Crystal Display. A 2-line by 16-character, display is available for the Series 155.

L/D: This is the Length to Diameter ratio in a pipe or duct between two locations. This non dimensional parameter is a comparative metric used to measure the distance between a flow disturbance and a measurement point. Both upstream, and downstream values are needed to quantify an installation.

MASS FLOW: Mass per unit time (i.e. Kg/s). This is the standard volumetric flow multiplied by the standard density.

MENU-STATE: A viewing or display screen of the LCD. See drawing DCN 340155-26 in Appendix A for a comprehensive listing of the menu-states.

MENU SCREEN: Any screen where data is presented or can be changed. Menu screens are found within or under the menu categories.

MENU CATEGORY: The top level screens within program or display mode are menu categories.

METER: A virtual single task device which measures an engineering value and may totalize its rate.

PARSE: This is the text processing algorithm required to separate data values from a string of data.

PPH: Pounds-per-Hour.

PPM: Pounds-per-Minute.

PROFILE: See Velocity Profile.

PROGRAM MODE: The set of display menus for programming or configuring the METER.

PSIA: Pounds per Square Inch, Absolute pressure reference.

REBOOT: When a computer restarts there is a delay from the power on until it is operating normally. During this time it is loading its programs, doing some testing and initializing things. Its output will not update until this completes.

SCFH: Standard Cubic Feet-per-Hour.

SCFM: Standard Cubic Feet-per-Minute.

SCMH: Standard Cubic Meters-per-Hour.

SCMM: Standard Cubic Meters-per-Minute

SCMS: Standard Cubic Meters-per-Second

SFPM: Standard Feet-per-Minute.

SMPS: Standard Meters-per-Second.

STANDARD VOLUMETRIC FLOW: is the ρv product multiplied by an area (like a pipe cross section), normalized to a standard density.

$$\begin{aligned}\text{Standard Volumetric Flow} &= \text{Area} \times (\text{Standard Velocity}) \\ &= A\rho v/\rho_s\end{aligned}$$

Where ρ is the actual density, v is the actual velocity and ρ_s is the standard gas density and A is the area.

STANDARD VELOCITY: is the ρv product normalized to a standard density.

$$\text{Standard Velocity} = \rho v/\rho_s \text{ with units of velocity}$$

Where ρ is the actual density, v is the actual velocity and ρ_s is the standard gas density. For air this is 0.07387 lb/ft³ at 25 °C and 29.92 in Hg.

VTM: Velocity Temperature Mapping. This is a calibration method where data at several temperatures are loaded into the flow meter. Flow signal linearization and then interpolation between the different temperature data sets are performed. This method is a second order correction to the sensors response and provides a more accurate temperature compensated flow measurement.

VELOCITY PROFILE: Due to drag and viscous fluid flow, the velocity in a duct tends to be its highest in the center and goes to zero at the duct walls. This shape is bullet nose at low velocities known as laminar, and flattens out at the higher more turbulent flow rates. A velocity dependent correction factor is measured based on an in-situ calibration to accurately convert the sensors velocity reading to the true average for computing flow or mass flow.

Appendix A

Product Brochure

367001 Series 155 Brochure

SERIES

155

MASS FLOW
COMPUTERS

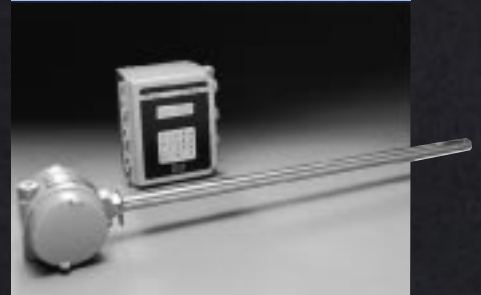

KURZ
INSTRUMENTS INC.™

DESCRIPTION

Known as ADAM™, these “Smart” Mass Flow Computers are state-of-the-art, microprocessor-based, versatile system transmitters. The various models operate one or more Kurz Mass Flow Elements including Series 410, 452, 454FT, 502, 504FT, 510, 532, 522-UHP, 542, K-BAR 16, K-BAR 24, K-BAR 2000, the Series IK-4200 Isokinetic Sampling Systems and the Series 730 Electric Rotary Ramp Control Valves. The Series 155 integrates the functions of flow and temperature measurement, flow totalization, alarms, data acquisition, input/output calibration and closed loop flow control.

Models are available to operate up to 22 separate mass flow or temperature elements. A METER may be defined to represent the output of a mass flow element or the average value of several mass flow or temperature elements such as the K-BAR 24 Multi-Point Insertion Mass Flow Elements. The smaller Model 155's have two analog 4-20 mA outputs; the larger models support up to eight 4-20 mA outputs. All Models include a convenient 2 line, 16 character LCD display and 20 button keypad to display the measurements, input all calibration and set-up data, and perform input/output calibration of each input and each analog output. In addition, each Model has a RS-232C communication port which allows an IBM compatible PC to be used to “ECHO” the keypad functions. Several models may be configured for dual redundancy. Get the best—Get Kurz!

**KEY FEATURES**

- ▶ Easy-to-use menu for display and set-up with HELP screens.
- ▶ Two-line 16 character Liquid Crystal Display (LCD).
- ▶ 20 button keypad (built-in terminal).
- ▶ 24 hour clock/calendar, year 2000 compliant.
- ▶ Up to 22 sensor inputs; mass flow rate, temperature and 4-20 mA reference inputs.
- ▶ Ability to group one or more inputs as a METER and to define a METER as the sum/difference of other METERS, up to a maximum of 16 METERS.
- ▶ Up to eight 4-20 mA outputs.
- ▶ Up to eight 5-amp alarm relays.
- ▶ English or Metric units (SFPM, SCFM, SCFH, PPH, °F; SMPS, SCMM, SCMh, KGH, °C).
- ▶ Multi-point calibration factor for each METER.
- ▶ User-entered METER I.D. number and flow area.
- ▶ Automatic sensor out-of-tolerance indication, alarm and re-averaging for multi-point flow elements.
- ▶ Easy input/output calibration—all digital—no pots!
- ▶ Lagrangian polynomial calibration data interpolation for maximum accuracy.
- ▶ User-selectable digital filtering for all input channels.
- ▶ Operating temperatures range -25°C to 60°C.
- ▶ Built-in flow totalizers and elapsed time.
- ▶ Non-Incendive Approval on all models.
- ▶ Paper tape printer.
- ▶ Technician and user access codes for security.
- ▶ Echo type RS-232C communication port for terminal operation and setup.
- ▶ Optional NEMA 4, NEMA 4X, NEMA 7 and 19" EIA rack enclosures.
- ▶ Configuration Upload/Download software using IBM-compatible computers.
- ▶ Meets all the requirements for 40CFR 75, stack flow monitors (EPA Title IV) including flow interference and daily Drift Check (except 155Jr).
- ▶ Velocity/Temperature/Mapping (VTM) for wide ranging, process temperature and velocity.
- ▶ Identical software menus for all Models.
- ▶ Built-in field calibrators for all Models.
- ▶ Optional RS-232C data port on all models; RS-485 on 155C-2, 155E-2 and 155E-RM2.
- ▶ Choice of using optically isolated loop-powered or self-powered 4-20 mA outputs.
- ▶ Optional mass flow control of up to 4 separate In-Line Mass Flow Elements.
- ▶ Optional automatic isokinetic particulate sampling of up to four sample streams.
- ▶ Optional “Flow Perfect” sensor array configuration correction factor with “Kick-Out Count” for multi-point averaging configurations.
- ▶ EMI Approvals: CE compliance.
- ▶ Optional pulsed flow totalizer outputs.
- ▶ Optional redundant configuration using two Series155 Mass Flow Computers.

SERIES 155 MASS FLOW COMPUTERS

ORDERING INFORMATION

SERIES 155 NOMENCLATURE	
Term	Description
Input Channel	Current inputs to the Series 155 representing Kurz mass flow, temperature and flow control reference inputs. Input channels are labeled A, B...
Flow Perfect®	A unique configuration correction software algorithm for Insertion Mass Flow Elements that is used with velocity arrays. Flow Perfect automatically corrects for velocity sensors that are "kicked-out" of the average because readings are out-of-tolerance. Flow Perfect requires that field calibration data for each velocity sensor be entered in the Series 155.
METER	A METER may be Mass Flow Meter, Temperature Meter, a reference Mass Flow Meter representing a flow control set-point, or a Mass Flow Meter representing the sum and/or difference of several Mass Flow Meters. A METER can be assigned an I.D., area, correction factors, outputs, alarms, etc.

TABLE 1: SERIES 155 INPUT/OUTPUT/POWER CAPABILITIES							
Model Number	Input Power (Note 1)	Number of Input Channels	Optional Analog Outputs	Max. Meter	Maximum Current (mA)		
					40°C	50°C	60°C
155Jr	AC	2	1,2	4	625	575	525
155Jr	DC	6	1,2	8	3,000	3,000	3,000
155A	AC	6	1,2	8	1,725	1,625	1,525
155A	DC	6	1,2	8	3,000	3,000	3,000
155B	AC	6	1,2	8	3,400	3,200	3,000
155B-RM	AC	6	1,2	8	3,400	3,200	3,000
155B-RM	DC	6	1,2	8	3,000	3,000	3,000
155C-2	AC	22	1,2,4,6,8	16	6,000	5,500	4,550
155C-2	DC	22	1,2,4,6,8	16	11,000	11,000	11,000
155E-2	AC	22	1,2,4,6,8	16	11,000	11,000	11,000
155C-RM2	AC	22	1,2,4,6,8	16	6,000	5,500	4,500
155C-RM2	DC	22	1,2,4,6,8	16	11,000	11,000	11,000
155E-RM2	AC	22	1,2,4,6,8	16	11,000	11,000	11,000

Note 1: When sizing the external 24VDC power supply, add 500 mA to the required total sensor current.

TABLE 2: SERIES 155 AND MASS FLOW ELEMENT SELECTION CHART					
Mass Flow Models	Sensor Type	Number of Loop-powered Flow Channels	Number of 4-20 mA Flow Channels	Number of 4-20 mA Temp. Channels	Maximum Sensor Current (MA)
452, K-BAR 24, 542, 502-40 thru-96,	FD-MT FD-HHT	1	0	0	500
454FT, 504FT-40 thru-96 K-BAR 2000	FD-MT FD-HHT	0	1	1	500
452T, 542T, K-BAR 24	FDT-MT FDT-HHT	1	0	1	520
502-6A thru-32 522, 532, K-BAR16	MD	1	0	0	400
504FT-6A thru-32	MD	0	1	1	400
410, 510	CD	1	0	0	250

TABLE 3: SERIES 155 FEATURES AND OPTIONS						
Model Number	Input Power	Opt. Alarm Relays	Optional Paper Tape Printer	Calib. & EPA Drift Check (Note 1)	Opt. Flow Control Loops (Note 2)	Redundant Config. (Note 3)
155Jr	AC	4	NA	NA	1	OPT
155Jr	DC	4	NA	NA	1,2	OPT
155A	AC	4	NA	STD	1,2	OPT
155A	DC	4	NA	STD	1,2	OPT
155B	AC	4	NA	STD	1,2	OPT
155B-RM	AC	4	OPT	STD	1,2	OPT
155B-RM	DC	4	OPT	STD	1,2	OPT
155C-2	AC	8	NA	STD	2,4	OPT
155C-2	DC	8	NA	STD	2,4	OPT
155E-2	AC	8	NA	STD	2,4	OPT
155C-RM2	AC	8	OPT	STD	2,4	OPT
155C-RM2	DC	8	OPT	STD	2,4	OPT
155E-RM2	AC	8	OPT	STD	2,4	OPT

Note 1: This Feature has been designed primarily for use with one Mass Flow Meter such as the average of several K-BAR 24 Mass Flow Elements, the average of several Single-Point Insertion Mass Flow Elements or a single In-Line Mass Flow Element. If an acknowledgment relay is desired, one additional input channel, alarm relay and METER is required.

Note 2: When a Kurz In-Line Mass Flow Element is used with a Series 730 Control Valve and an isolated external set-point reference (4-20 mA) is supplied, one 4-20 mA input channel and one METER must be allocated for each control loop.

Note 3: The customer must specify a Redundancy Kit (see 155 Accessories).

TABLE 4: SERIES 155 PARENT NUMBERS, ENCLOSURE DESCRIPTION, SAFETY APPROVAL (Note 1)			
Model Number	Parent Number	Enclosure Description	Safety Approval
155Jr	750101	NEMA 4X Fiberglass (Note 2)	Ex nC II T4 (Cl. I, Div. 2, GPS. A, B, C, D, T4); CSA
155Jr-ExW	750105	NEMA 4/7, Aluminum with window	Cl. I, Div. 1, GPS. B, C, D
155A	750206	NEMA 4X Fiberglass (Note 2)	Ex nC II T4 (Cl. I, Div. 2, GPS. A, B, C, D, T4); CSA
155A-ExW	750208	NEMA 4/7, Aluminum with window	Cl. I, Div. 1, GPS. B, C, D
155B	750235	NEMA 4X Fiberglass (Note 2)	Ex nC II T4 (Cl. I, Div. 2 GPS. A, B, C, D, T4); CSA
155B-RM	750237	Rack-Mount, 19" EIA (Note 2)	Ex nC II T4 (Cl. I, Div. 2 GPS. A, B, C, D, T4); CSA
155C-2	750257	NEMA 4 painted steel (Note 2)	Ex nC II T4 (Cl. I, Div. 2 GPS. A, B, C, D, T4); CSA
155C-RM2	750258	NEMA 4 painted steel (Note 2)	Ex nC II T4 (Cl. I, Div. 2 GPS. A, B, C, D, T4); CSA
155E-2	750272	NEMA 4 painted steel (Note 2)	Ex nC II T4 (Cl. I, Div. 2 GPS. A, B, C, D, T4); CSA
155E-RM2	750278	Rack-Mount, 19" EIA (Note 2)	Ex nC IIC T4 (Cl. I, Div. 2 GPS. A, B, C, D, T4); CSA

Note 1: Refer to the outline drawings of the Series 155 Mass Flow Computer brochure for dimensions, net wt., and shipping wt., etc. All models have CE Compliance.

Note 2: LCD/Keypad is mounted on cover, with weatherproof, flexible polycarbonate overlay.

SERIES 155 MASS FLOW COMPUTERS

PART NUMBER GENERATION PROCEDURE

With the selected Parent Number, specify the entire Part Number by selecting an Option for each Feature as shown in the example below.

750101-04-01-05-04-01-01-88-01-01-00-01

Parent Number F1 F2 F3 F4 F5 F6 F7 F8 F9 F10 F11

SUMMARY OF FEATURES	
Feature	Feature Description
1	Number of 4-20 mA Outputs
2	Number of 0-5VDC Analog Outputs
3	Alarm Relays, Flow Control Drivers, Pulsed Outputs
4	Built-in Calibrators
5	Input Power
6	Terminal Communication and Data Ports
7	Printer Option
8	Series 155 Software Version/Chip Set
9	Number of Loop-Powered Mass Flow Sensor Input Channels
10	Number of 4-20 mA Mass Flow, Temperature or Reference Input Channels
11	Number of METERS

FEATURE 1: NUMBER OF 4-20 mA OUTPUTS			
Option	Number of Outputs	Models	Description
88	0	All	No 4-20mA Outputs
04	1	All	Loop-powered AC/DC isolated, or self-powered AC non-isolated, user selected.
05	2	All	
06	4	155C-2, 155C-RM2, 155E-2, 155E-RM2	
07	6		
08	8		

FEATURE 2: 0-5 VDC ANALOG OUTPUTS (NOTE 1)		
Option	Number of Outputs	Description
88	0	ALL
01	1	
02	2	
04	4	
06	6	155C-2, 155C-RM2, 155E-2, 155E-RM2
08	8	

Note 1: The number of analog 0-5VDC outputs must be equal to or the number of 4-20 mA outputs selected in Feature 1.

FEATURE 3: ALARM RELAYS, CONTROL DRIVERS, PULSED OUTPUTS	
Option	Description (Note 1)
88	No alarms, relays, or control driver outputs; all Models.
05	Four alarm relays, (5 A. 24 VAC/VDC); Models 155Jr, 155A, 155B, 155B-RM.
06	Eight alarm relays (5 A. 24 VAC/VDC); Models 155C-2, 155C-RM2, 155E-2, 155E-RM2.
07	Four alarm relays, (5 A. 24 VAC/VDC), one flow control driver for Kurz 730 control valve; Models 155Jr, 155A, 155B, 155B-RM.

FEATURE 3: ALARM RELAYS, CONTROL DRIVERS, PULSED OUTPUTS (Continued)	
Option	Description (Note 1)
08	Eight alarm relays, two flow control drivers for Kurz 730 control valves; Models 155C-2, 155C-RM2, 155E-2, 155E-RM2.
09	Four alarm relays, two flow control drivers for Kurz 730 control valves; Models 155Jr (DC), 155A, 155B, 155B-RM.
10	Eight alarm relays, four flow control drivers for Kurz 730 control valves; Models 155C-2, 155C-RM2, 155E-2, 155E-RM2.
11	Eight alarm relays, two flow control drivers with analog control signal for driving variable speed motors and position-input vanes and dampers, and valves 0-10 VDC up to 20 mADC output. Models 155C-2, 155C-RM2, 155E-2 and 155E-RM2.
12	Four alarm relays, two pulsed flow totalizer outputs, Models 155Jr, 155A, 155B, 155B-RM
13	Four alarm relays, one flow control driver, and two pulsed flow totalizer outputs; Models 155Jr, 155A, 155B, 155B-RM.
14	Eight alarm relays, eight pulsed flow totalizer outputs; Model 155C-2, 155C-RM2, 155E-2, 155E-RM2.
15	Eight alarm relays, two flow control drivers, four pulsed flow totalizer outputs; Models 155C-2, 155C-RM2, 155E-2, 155E-RM2.

Note 1: When alarm or alarm relays are ordered the 4th (Models 155Jr, 155A, 155B, 155B-RM) or 8th (Models 155C-2, 155C-RM2, 155E-2, 155E-RM2) alarm relay is automatically reserved for the Global Sensor "Kick-Out" feature.

FEATURE 4: BUILT-IN CALIBRATORS	
Option	Description
04	Built-in Electronic Calibrator. All versions of Model 155Jr.
06	Built-in Variable input (0-5 VDC) Electronic Calibrator with externally activated Flow Drift Check Circuit. User to initiate "zero" and "span" timing cycles by providing a contact closure for "zero" and one for "span". Includes ability to set one or two alarm relays to provide acknowledgement that "zero/span" Drift Check Circuit is operative (requires one additional relay, METER and input channel). Meets EPA requirements for flow monitors. Models 155A, 155B, 155B-RM, 155C-2, 155C-RM2, 155E-2, 155E-RM2 only.

FEATURE 5: INPUT POWER	
Option	Description
01	115 VAC 50/60 Hz; all Models.
02	230 VAC 50/60 Hz; all Models.
03	Isolated, 24 VDC, Models 155Jr, 155A, 155B-RM, 155C-2, 155C-RM2,

FEATURE 6: TERMINAL COMMUNICATION AND DATA PORTS	
Option	Description
88	RS-232C terminal communication port; echoes display/keypad and allows use of a computer terminal for programming, all Models.
01	RS-232C data port with standard output format and RS-232C terminal communication port as described above. Protocol furnished. All Models. This option must be ordered if a printer is ordered (Feature 7).
03	RS-485 data port with standard output format and RS-232C Terminal communication port as described above. Protocol furnished. Models 155C-2, 155C-RM2, 155E-2 and 155E-RM2 only.

SERIES 155 MASS FLOW COMPUTERS

FEATURE 7: PRINTER OPTION	
Option	Description
88	No printer.
05	Paper Tape Printer, requires that Feature 6, Option 01 (RS-232C Data Port) must also be ordered. The printer is mounted on the front panel. Models 155B-RM, 155C-RM2 and 155E-RM2.

FEATURE 8: SOFTWARE VERSION/CHIP SET	
Option	Description
01	Current software, includes Flow Control,VTM; English units.
11	Current software, includes Flow Control,VTM; Metric units.
02	Current software, includes Flow Control,VTM;"Flow Perfect" Multi-Point Array Correction Factor with "Kick-out Count"; English units.
12	Current software, includes Flow Control,VTM;"Flow Perfect" Multi-Point Array Correction Factor with "Kick-out Count"; Metric units.

FEATURE 9: NUMBER OF LOOP-POWERED MASS FLOW SENSOR INPUT CHANNELS	
Description	
Enter the number of input channels required for the loop-powered mass flow sensors being used with a Series 155. Enter two (2) digits. See Table 1 for the maximum number of input channels for each Model and the power supply current capability. Also see Table 2.	

FEATURE 10: NUMBER OF 4-20 mA INPUT CHANNELS	
Description	
Enter the number of input channels required for the 4-20 mA mass flow, temperature or reference inputs. Enter two (2) digits. (Enter 00 if no 4-20 mA inputs are required). See Table 1 for the maximum number of input channels for each Model. These inputs must be isolated from earth ground unless the Model 155 is used to supply the power.	

FEATURE 11: NUMBER OF METERS	
Descriptions	
Enter the total number of METERS required for the application. Enter two (2) digits. See Table 1 for the maximum number of METERS for each Model.	

SERIES 155 ACCESSORIES	
Part Number	Description
155-SW-350	Current Upload/Download/Dump/Record current software program for all Series 155s for use with IBM compatible PC 3.5" disk drive. Note: One copy is included with each Series 155.
170098	Stainless Steel Identification Tag, maximum of 4 lines of 32 characters each, 1.25" x 3". Specify information with order.
700185-01	Model 185-4, RFI, EMI and Surge Protection Enclosure, for up to 5 two-wire circuits, NEMA 4 painted steel, 8"L x 6"W x 4"D.
700185-02	Model 185-8, RFI, EMI and Surge Protection Enclosure, for up to 10 two-wire circuits, NEMA 4 painted steel, 8"L x 6"W x 4"D.
700185-03	Model 185-20, RFI, EMI and Surge Protection Enclosure, for up to 20 two-wire circuits, NEMA 4 painted steel, 14"H x 12"W x 6"D.
700185-04	Model 185-2 RFI, EMI and Surge Protection Enclosure for up to 2 two-wire circuits. NEMA 4/7 painted aluminum, wall-mounted.
700011-01	Rack Mounting Kit for one Model 155Jr Mass Flow Computer, 10.5"H x 19" EIA Panel.
700011-02	Rack Mounting Kit for two Model 155Jr Mass Flow Computers, 10.5"H x 19" EIA Panel.

SERIES 155 ACCESSORIES (Continued)	
Part Number	Description
700012-02	Dual Mass Flow Computer Redundancy Kit, includes Remote Flow Element Terminal Junction Box, cables, conduit, and conduit fittings. Enclosure must be located within two feet of Mass Flow Computers. Models 155C-2, 155C-RM2, 155E-2 and 155E-RM2. AC or DC input power.
700012-04	Dual Mass Flow Computer Redundancy Kit, for Models 155Jr, 155A and 155B-RM. AC or DC input power.

ORDERING INFORMATION

Using the Series 155 Part Number/Order Sheet:

- A** Enter the complete Series 155 Part Number (Section A).
- B** Enter the accessories Part Numbers.
- C** Fill out the configuration chart (Section B).
- D** Contact the Kurz Representative or the Kurz Factory to place the order or to obtain additional information.

SPECIFICATIONS

Input Channels:

18.2 bit resolution
0 to 5VDC, 13.2 bit accuracy, ± 30 ppm/ $^{\circ}$ C

Analog Outputs:

Resolution and Accuracy: 12 bit
4-20 mA, Isolated (500 VAC or 707 VDC),
7 to 50 V compliance: at 24 VDC $R_{max} = 850 \Omega$
Non-isolated, $R_{max} = 400 \Omega$, ± 110 ppm/ $^{\circ}$ C
0-5V: 250 Ω min. load impedance ± 30 ppm/ $^{\circ}$ C

Measurement Rate:

0.1 s/channel + 0.2 S

Filter Time Constant:

0-3600 S

LCD Display Update:

Every 2 seconds

Serial Port Baud Rate:

9,600

Relays:

5 A, 24 VAC/DC, sealed

Environment:

-25 to 60 $^{\circ}$ C, 10 to 90% RH, noncondensing

Power:

115/230 VAC $\pm 10\%$ 50/60 Hz; 24 VDC $\pm 10\%$

Safety Approvals:

Non-Incendive IEC 79-15, Ex nC II T4 (Cl. I, Div. 2, GPS. A, B, C, D, T4); CSA;

EMI Approvals:

CE compliance: light industrial: (EN 50081-2) for emissions, heavy industrial (EN 50082-2) for immunity and (EN 61000-4-5) for surges, all Models.

OUTLINE DRAWINGS

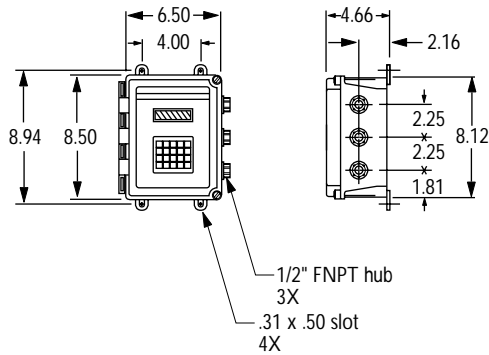

Model 155Jr, Parent No. 750101

NET WT. 4.0 lbs.
SHIP WT. 6.0 lbs.

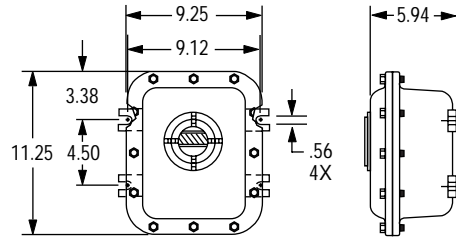

Model 155Jr-ExW, Parent No. 750105

NET WT. 23 lbs.
SHIP WT. 29 lbs.

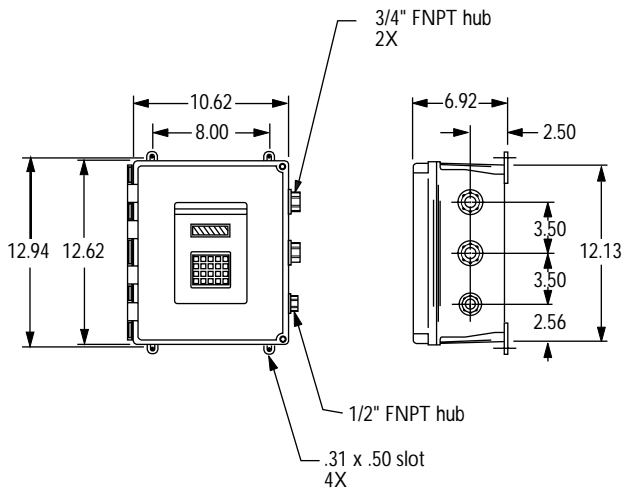

Model 155A, Parent No. 750206

NET WT. 11 lbs.
SHIP WT. 13 lbs.

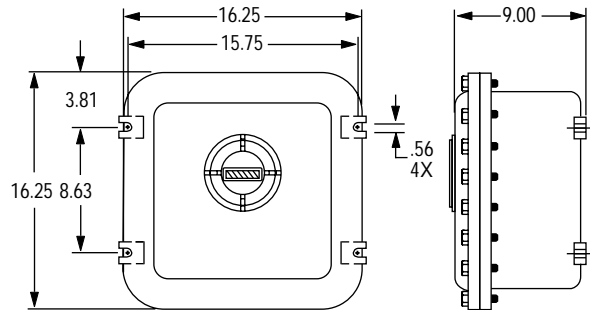

Model 155A-ExW, Parent No. 750208

NET WT. 72 lbs.
SHIP WT. 77 lbs.

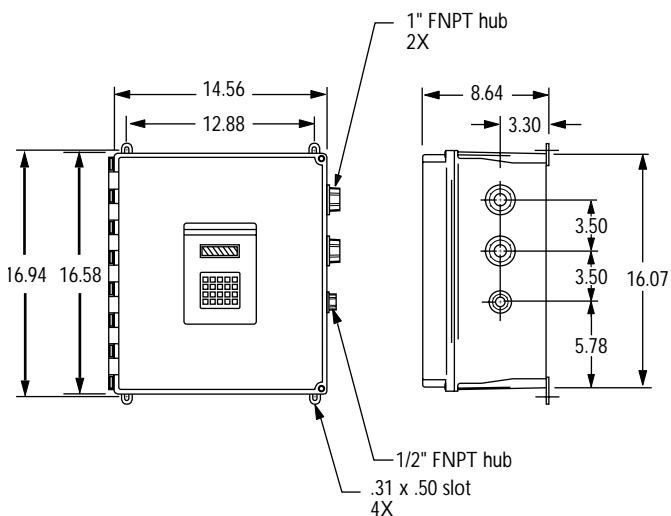

Model 155B, Parent No. 750235

NET WT. 21 lbs.
SHIP WT. 27 lbs.

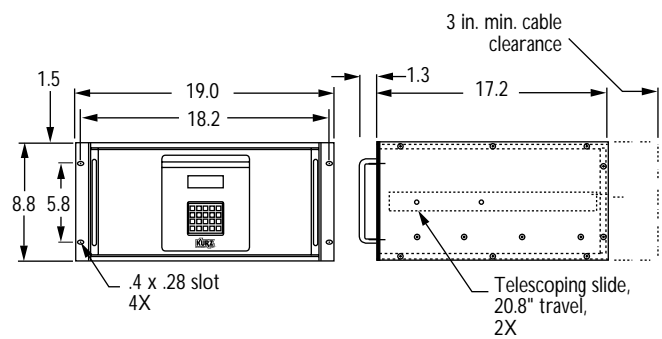

Model 155B-RM, Parent No. 750237

NET WT. 20 lbs.
SHIP WT. 25 lbs.

OUTLINE DRAWINGS

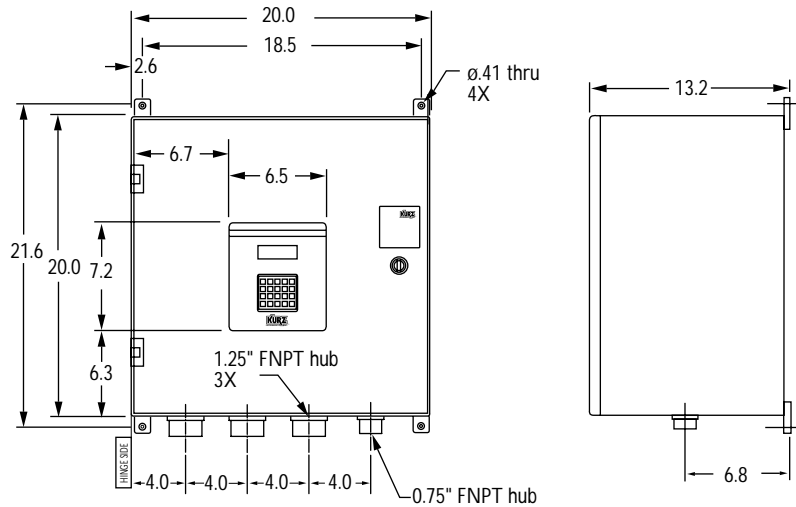

Model 155C-2, Parent No. 750257

NET WT. 48 lbs.
SHIP WT. 55 lbs.

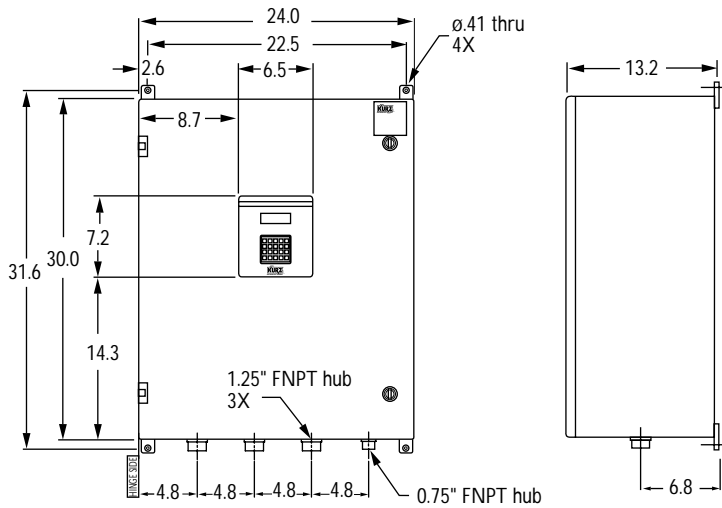

Model 155E-2, Parent No. 750272

NET WT. 75 lbs.
SHIP WT. 90 lbs.

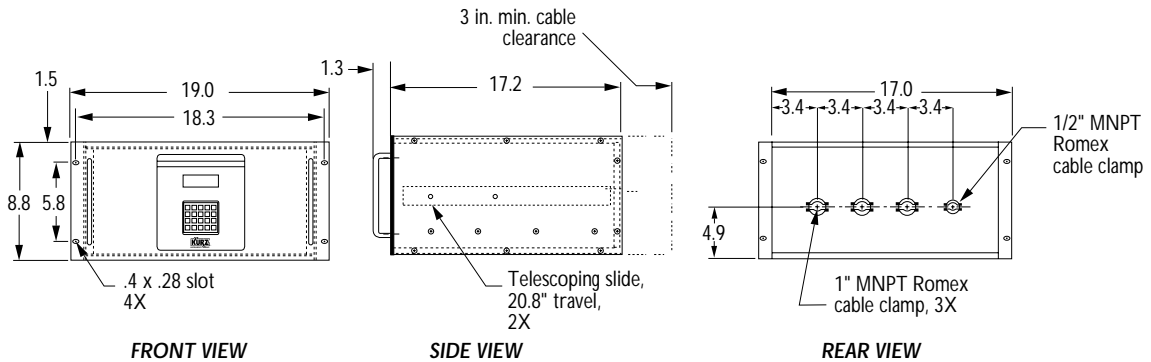

Model 155C-RM2, Parent No. 750258
Model 155E-RM2, Parent No. 750278

NET WT. 25 lbs.
SHIP WT. 32 lbs.

**The leader in Mass Flow
Technology for Process and
Environmental Measurements**



Kurz Instruments, Inc.

2411 Garden Road, Monterey, CA 93940

800-424-7356 ■ 831-646-5911 ■ Fax 831-646-8901

www.kurz-instruments.com

e-mail: sales@kurz-instruments.com

Appendix B

Product Approvals

The declaration of CE compliance and safety for the Series 155 read some thing like the following text. A table of the actual documents has been provided for your reference. If the actual certificate should be needed you can contact Kurz Instruments, Inc. for a copy.

Series 155 Declaration of Safety Compliance

In accordance with Directive 89/336/EEC for Industrial, Scientific and Medical (ISM) equipment, all the Series 155 are CE compliant. All Mass Flow Computers in the Series 155 have been designed and manufactured in accordance with the EN 50081-1 light industrial, commercial and residential equipment emissions standard and the EN 50082-2 heavy industrial equipment immunity standard. All of the 155 Series have been designed and manufactured according to the electrical safety principles embodied in the Low Voltage Directive (73/23/EEC and 93/68/EEC) and uses good engineering practice where other aspects of safety are concerned. All models exceed the low voltage directive by having a non-incendive safety approval from CSA (Ex nA II T4).

Jerry Kurz
President/Owner

December 1, 2000

Kurz Document #	Description
430005	Declaration of CE compliance for 155Jr/Jr-Tr
430010	Declaration of CE compliance for 155A/B/B-RM
430021	Declaration of CE compliance for 155C-2/E-2/RM2
430004	Non-incendive Safety approval (Ex nC II T4) for 155Jr from KEMA
430022	Non-incendive Safety approval (Ex nC II T4) for 155Jr/Jr-Tr from CSA
430019	Non-incendive Safety approval (Ex nC II T4) for 155A/B/B-RM from CSA
430031	Non-incendive Safety approval (Ex nC II T4) for 155C-2/E-2/RM2 from CSA

Appendix C

Field Wiring Diagrams

340155-29	155Jr
340155-44	155A
340155-45	155B
340155-50	155Jr-DC
340155-55	155C-2/E-2/RM2 (two sheets)
340155-57	155C-2/E-2/RM2 with pulsed totalizer outputs

REVISIONS					
REV.	DESCRIPTION	BY	CHKD	APRVD	DATE
A	RELEASE TO PRODUCTION	DFS	TW	BL	10/6/92
B	REVISED PER ECO B47090	DFS	TW	BBB	8/19/93
C	REVISED PER ECO B47123	DFS	TW	BBB	10/18/93
D	REVISED PER ECO B47138	DFS	TW	CHM	2/18/94
E	REVISED PER ECO B47149	ADK	TW	CHM	3/20/95
F	REVISED PER ECO B47268	DFS	BBB	TW	6.9.95
G	REVISED PER ECO B47280	GF	BBB	GF	8/16/95
H	REVISED PER ECO B47285	FM	BBB	TW	9-12-95
J	REVISED PER ECO B47301	ADK			

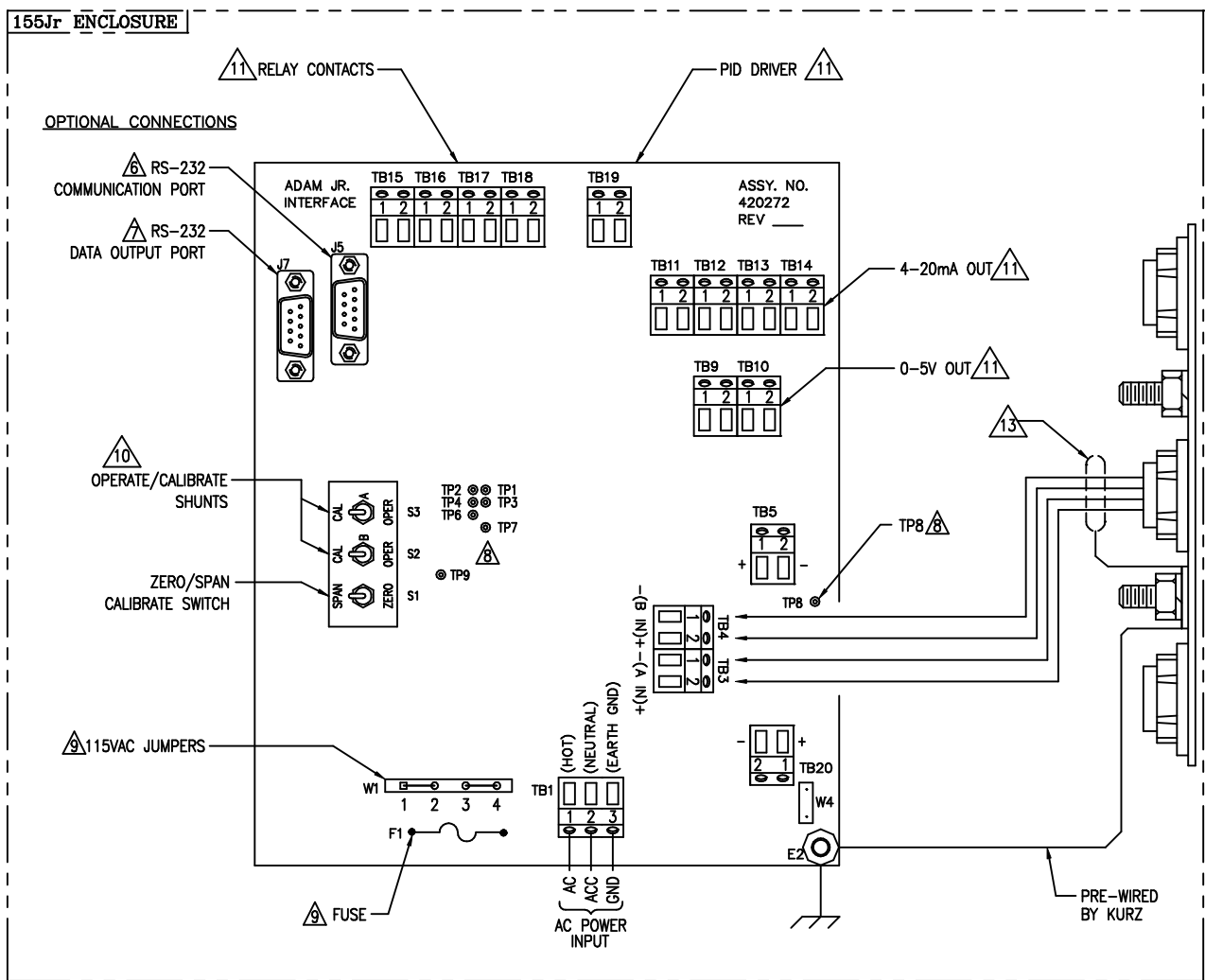

SAMPLE DIAGRAMS, 4-20mA CONNECTIONS

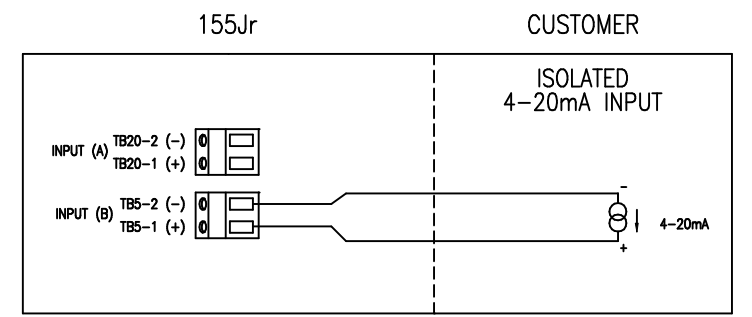
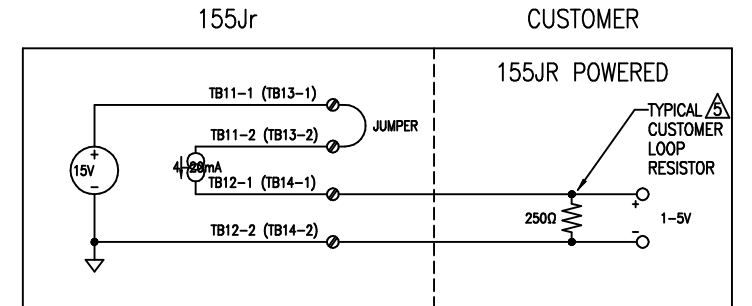
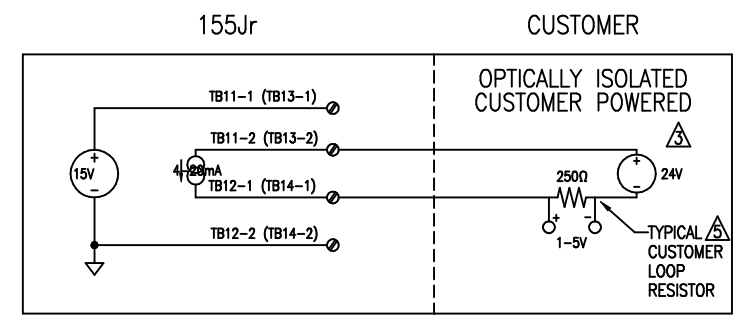

NOTES:

- THIS WIRING DIAGRAM IS USED IN CONJUNCTION WITH PARENT NUMBERS 750101, 750104, 750105, 750106 AND 750107.
- REF. DESIGNATORS AND PIN NUMBERS ARE FOR REF. ONLY, AND MAY NOT APPEAR ON COMPONENTS

- 15 TO 50 VDC.
- TB3-1 THRU TB4-1 (INPUTS A THRU B) 0-5 VDC MAX. TB3-2 THRU TB4-2 (OUTPUTS A THRU B) 18 TO 24 VDC.
- MAXIMUM LOOP SERIES RESISTOR VALUE=500Ω.
- RS-232 COMMUNICATIONS PORT

J5	PIN	CUSTOMER CONNECT
N/C	1	9 PIN TO 9 PIN
TXD1	2	CABLE, STRAIGHT
RXD1	3	THROUGH
DTR	4	
GND	5	
DSR	6	
RTS	7	
CTS	8	
N/C	9	

- RS-232 DATA OUTPUT PORT

J7	PIN	CUSTOMER CONNECT
N/C	1	9 PIN TO 9 PIN
TXDO	2	CABLE, STRAIGHT
RXDO	3	THROUGH
DTR	4	
GND	5	
DCDO	6	
RTSO	7	
CTSO	8	
N/C	9	

- TEST POINTS.
 - TP1 +2.500 REF
 - TP2 +5V
 - TP3 -9V
 - TP4 +10V
 - TP6 +12V
 - TP7 +15V
 - TP8 GND REF (LEAD ON R1)
 - TP9 INPUT CAL.

- 115VAC (STD.)

W1	1	2	3	4
----	---	---	---	---

 F1 IS 0.3 AMP 3AG SLO-BLO (KURZ P/N 630055)
- 230VAC (OPT.)

W2	1	2	3	4
----	---	---	---	---

 F1 IS .15 AMP 3AG SLO-BLO (KURZ P/N 630054)

- SHUNT POSITION
 - CHANNEL CALIBRATE
 - OPERATE MODE

- OPTIONAL CONNECTIONS
 - TB5 - 1 (+) } INPUT B
 - TB5 - 2 (-) }
 - TB9 - 1 (+) 0-5V } ANALOG
 - TB9 - 2 GND } OUT 1
 - TB10 - 1 (+) 0-5V } ANALOG
 - TB10 - 2 GND } OUT 2
 - TB11 - 1
 - TB11 - 2 } 4-20mA OUT 1
 - TB12 - 1
 - TB12 - 2 }
 - TB13 - 1
 - TB13 - 2 } 4-20mA OUT 2
 - TB14 - 1
 - TB14 - 2 }
 - TB15 - 1
 - TB15 - 2 } ALARM OUT 1
 - TB16 - 1
 - TB16 - 2 } ALARM OUT 2
 - TB17 - 1
 - TB17 - 2 } ALARM OUT 3
 - TB18 - 1
 - TB18 - 2 } ALARM OUT 4
 - TB19 - 1 (+) } PID #1
 - TB19 - 2 (-) }
 - TB20 - 1 (+) } INPUT A
 - TB20 - 2 (-) }

- EXTERNAL INPUT OPTION
 - TB20-1 INPUT A (+ EXT.)
 - TB20-2 INPUT A (- EXT.)
 - TB5-1 INPUT B (+ EXT.)
 - TB5-2 INPUT B (- EXT.)
- CONNECT INPUT/OUTPUT SHIELDS TO GROUND BUS BAR.
- W4 JUMPER REQUIRED TO CONNECT DC GND TO EARTH GND (E2).

UNLESS OTHERWISE SPECIFIED DIMENSIONS ARE IN INCHES		APPROVALS		KURZ INSTRUMENTS, INC.	
TOLERANCES ARE		DRAWN BY	DATE	WIRING DIAGRAM, HOOK-UP, 155 JR.	
FRACTIONS ± 1/16		D.F. SINGLETON	9/29/92		
ANGLES ± 1°-0'		CHECKED BY	DATE		
DECIMALS		T. WILSON	10/6/92		
.X ± 0.1		APPROVED	DATE		
.XX ± 0.03		B. LESKO	10/6/92		
.XXX ± 0.003					
ORIG. RELEASE DATE					
NEXT ASSEMBLY					
DWG. SIZE	DWG. NO.	340155-29		REV.	J
D	SCALE	NONE		SHEET	1 OF 1

REVISIONS					
REV.	DESCRIPTION	BY	CHKD	APRVD	DATE
H	REDRAWN & REVISED PER ECO# C47265	GF	GF	GF	11-6-07

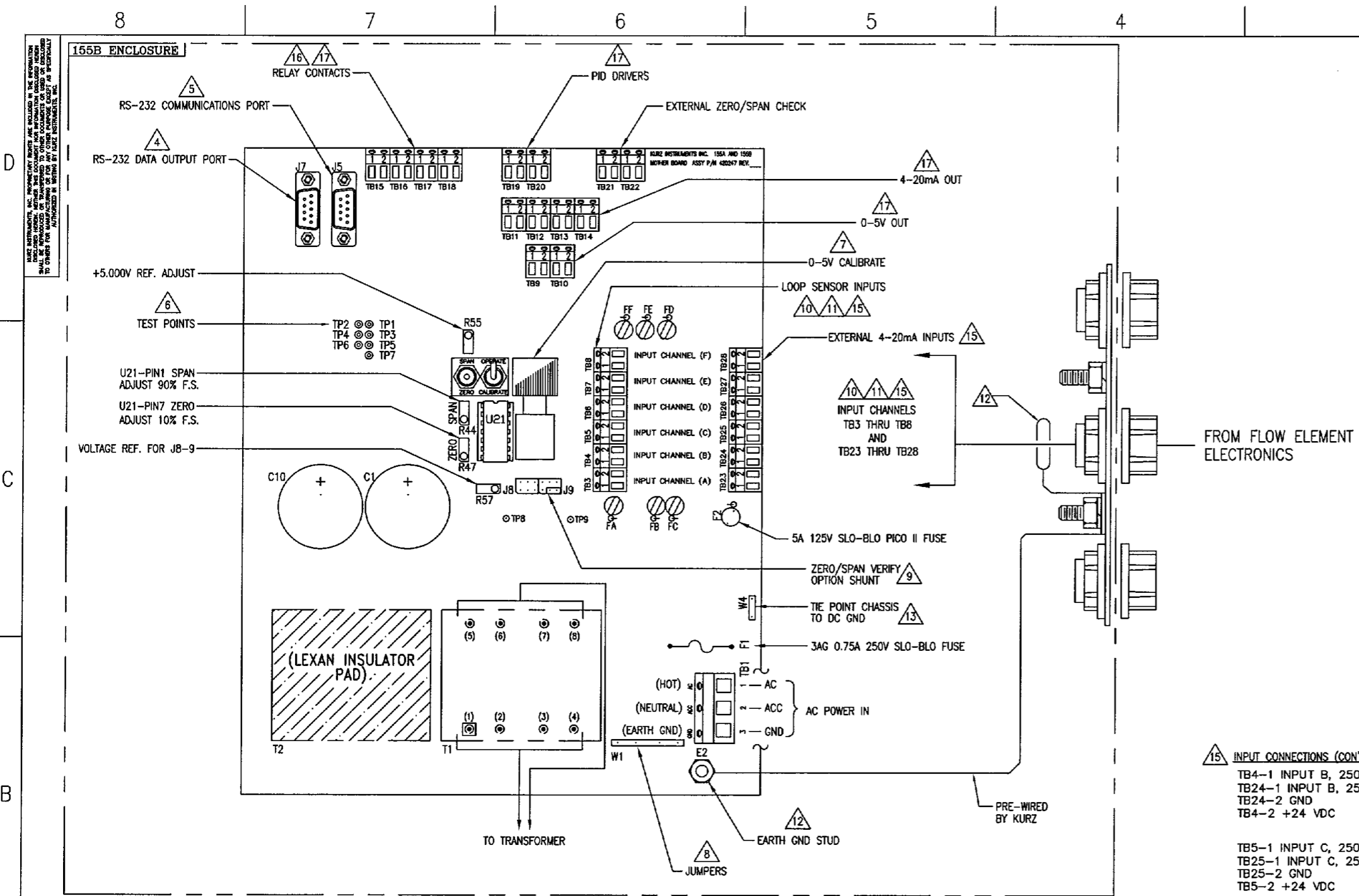

SAMPLE DIAGRAMS, 4-20mA CONNECTIONS

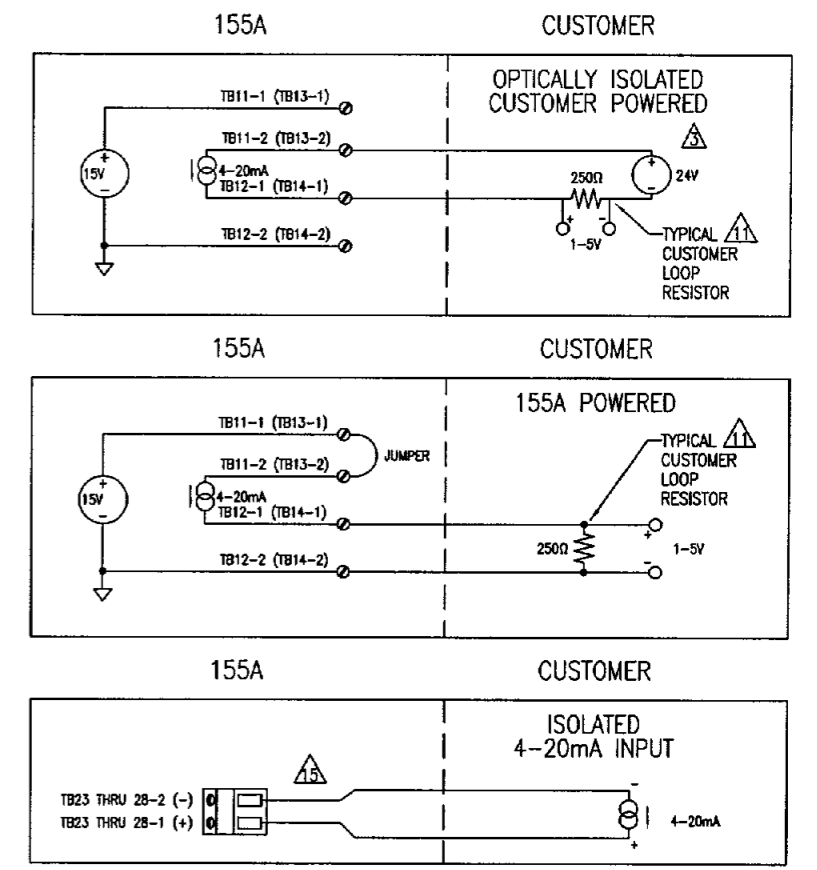

- 15 INPUT CONNECTIONS (CONT.)**
- TB4-1 INPUT B, 250 Ω OR 5 Ω CSR
 - TB24-1 INPUT B, 250 Ω OR 5 Ω CSR
 - TB24-2 GND
 - TB4-2 +24 VDC
- INPUT CHANNEL (B)**
- TB5-1 INPUT C, 250 Ω OR 5 Ω CSR
 - TB25-1 INPUT C, 250 Ω OR 5 Ω CSR
 - TB25-2 GND
 - TB5-2 +24 VDC
- INPUT CHANNEL (C)**
- TB6-1 INPUT D, 250 Ω OR 5 Ω CSR
 - TB26-1 INPUT D, 250 Ω OR 5 Ω CSR
 - TB26-2 GND
 - TB6-2 +24 VDC
- INPUT CHANNEL (D)**
- TB7-1 INPUT E, 250 Ω OR 5 Ω CSR
 - TB27-1 INPUT E, 250 Ω OR 5 Ω CSR
 - TB27-2 GND
 - TB7-2 +24 VDC
- INPUT CHANNEL (E)**
- TB8-1 INPUT E, 250 Ω OR 5 Ω CSR
 - TB28-1 INPUT E, 250 Ω OR 5 Ω CSR
 - TB28-2 GND
 - TB8-2 +24 VDC
- INPUT CHANNEL (F)**
- TB3-1 INPUT A, 250 Ω OR 5 Ω CSR
 - TB23-1 INPUT A, 250 Ω OR 5 Ω CSR
 - TB23-2 GND
 - TB3-2 +24 VDC
- INPUT CHANNEL (A)**
- 16 CHANNEL KICK OUT ALARM IS THE LAST ALARM IN THE CONFIGURATION.**
- 17 OPTIONAL CONNECTIONS**
- TB9 - 1 (+) 0-5V ANALOG OUT 1
 - TB9 - 2 GND
 - TB10 - 1 (+) 0-5V ANALOG OUT 2
 - TB10 - 2 GND
 - TB11 - 1 (+) 15 VDC
 - TB11 - 2 A01 (+)
 - TB12 - 1 A01 (-)
 - TB12 - 2 GND
 - TB13 - 1 (+) 15 VDC
 - TB13 - 2 A02 (+)
 - TB14 - 1 A02 (-)
 - TB14 - 2 GND
 - TB15 - 1
 - TB15 - 2 ALARM OUT 1
 - TB16 - 1
 - TB16 - 2 ALARM OUT 2
- OPTIONAL CONNECTIONS (CONT.)**
- TB17 - 1 } ALARM OUT 3
 - TB17 - 2 }
 - TB18 - 1 } ALARM OUT 4
 - TB18 - 2 }
 - TB19 - 1 (+) } PID #1
 - TB19 - 2 (-) }
 - TB20 - 1 (+) } PID #2
 - TB20 - 2 (-) }
 - TB21 - 1 CONTACT POLE } SPAN
 - TB21 - 2 DC GND }
 - TB22 - 1 CONTACT POLE } ZERO
 - TB22 - 2 DC GND }

NOTES: (UNLESS OTHERWISE SPECIFIED).

- THIS WIRING DIAGRAM IS USED IN CONJUNCTION WITH PARENT NUMBER 750235.
- REF. DESIGNATORS AND PIN NUMBERS ARE FOR REF. ONLY, AND MAY NOT APPEAR ON COMPONENTS
- 15 TO 50 VDC.
- RS-232 COMMUNICATIONS PORT
- RS-232 DATA OUTPUT PORT
- TEST POINTS.
- RELAY CONTACTS
- CALIBRATION TEST POINTS.
- JUMPER LOCATION WHEN NOT USED. SEE MANUAL.
- FOR FLOW/TEMP. TRANSMITTER CONNECTION TO LOOP SENSOR INPUTS. CURRENT SENSE RESISTORS ARE REQUIRED FOR EACH CHANNEL USED. (250 OHM FOR K-BAR2000 & SERIES MFT PRODUCT LINES) (5 OHM FOR K-BAR-24, MODELS 452, 502, ETC.)
- MAXIMUM LOOP SERIES RESISTOR VALUE=500 Ω.
- CONNECT INPUT/OUTPUT SHIELDS TO CONDUIT HUB FITTINGS AND TO EARTH GND (E2).
- W4 JUMPER REQUIRED TO CONNECT DC GND TO EARTH GND (E2).
- MINIMUM WIRE SIZE: 18 GA. (EXCEPT SENSOR INPUT WIRES. SELECT CABLE LENGTH AND WIRE GAGE SO THAT THE LOOP RESISTANCE DOES NOT EXCEED 4.0 OHMS W/ K-BAR-24 (REFER TO MANUAL.) SMALLER GAGE FOR THE SERIES MFT PRODUCT LINE (K-BAR-2000, 454, 504, ETC.)
- INPUT CONNECTIONS

3 15 TO 50 VDC.

4 RS-232 COMMUNICATIONS PORT

PIN	CUSTOMER CONNECT
N/C	1 9 PIN TO 9 PIN
TXD1	2 CABLE, STRAIGHT
RXD1	3 THROUGH
DTR	4
GND	5
DSR	6
RTS	7
CTS	8
N/C	9

5 RS-232 DATA OUTPUT PORT

PIN	CUSTOMER CONNECT
N/C	1 9 PIN TO 9 PIN
TXD0	2 CABLE, STRAIGHT
RXD0	3 THROUGH
DTR	4
GND	5
DCD0	6
RTS0	7
CTS0	8
N/C	9

6 TEST POINTS.

- TP1 5.00 REF
- TP2 +5V
- TP3 -5V
- TP4 +10V
- TP5 -5V
- TP6 N/A
- TP7 +15V

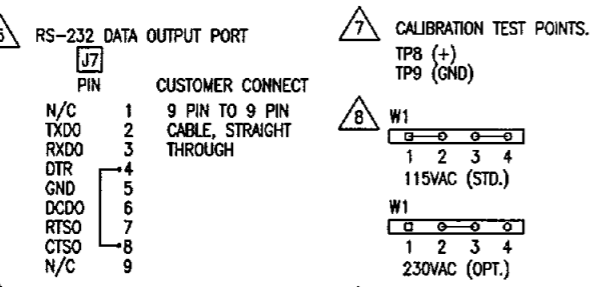

UNLESS OTHERWISE SPECIFIED DIMENSIONS ARE IN INCHES		APPROVALS		KURZ INSTRUMENTS, INC.	
TOLERANCES ARE		DRAWN BY	DATE	MODEL 155B W/ MODEL 90	
FRACTIONS ± 1/16		G. FOSTER	11/3/07	FIELD WIRING DIAGRAM	
ANGLES ± 1°-0'		CHECKED BY	DATE	DWG. SIZE	DWG. NO. 340155-45
DECIMALS		B. BURTON	11-6-07	SCALE	NONE
.X ± 0.1		APPROVED	DATE	SHEET	1/1
.XX ± 0.03					
.XXX ± 0.003					
N/A					
ORIG. RELEASE DATE	8/16/93				
NEXT ASSEMBLY					

KURZ INSTRUMENTS, INC. PROPRIETARY RIGHTS ARE INCLUDED IN THE INFORMATION DISCLOSED HEREIN. NEITHER THIS DOCUMENT NOR INFORMATION DISCLOSED HEREIN IS TO BE REPRODUCED, COPIED, OR TRANSMITTED IN ANY FORM OR BY ANY MEANS, ELECTRONIC OR MECHANICAL, INCLUDING PHOTOCOPYING, RECORDING, OR BY ANY INFORMATION STORAGE AND RETRIEVAL SYSTEM, WITHOUT THE WRITTEN PERMISSION OF KURZ INSTRUMENTS, INC.

REVISIONS					
REV.	DESCRIPTION	BY	CHKD	APRVD	DATE
A	INITIAL RELEASE	DFS	TW	BBB	05-22-1995
B	REVISED PER ECO # B47303	FGM	BBB	BBB	01-10-1995
C	REVISED PER ECO # B47301	ADK	BBB	BBB	08-12-1996
D	REVISED PER ECO # B47723	JLM	BBB	BBB	10-19-2000

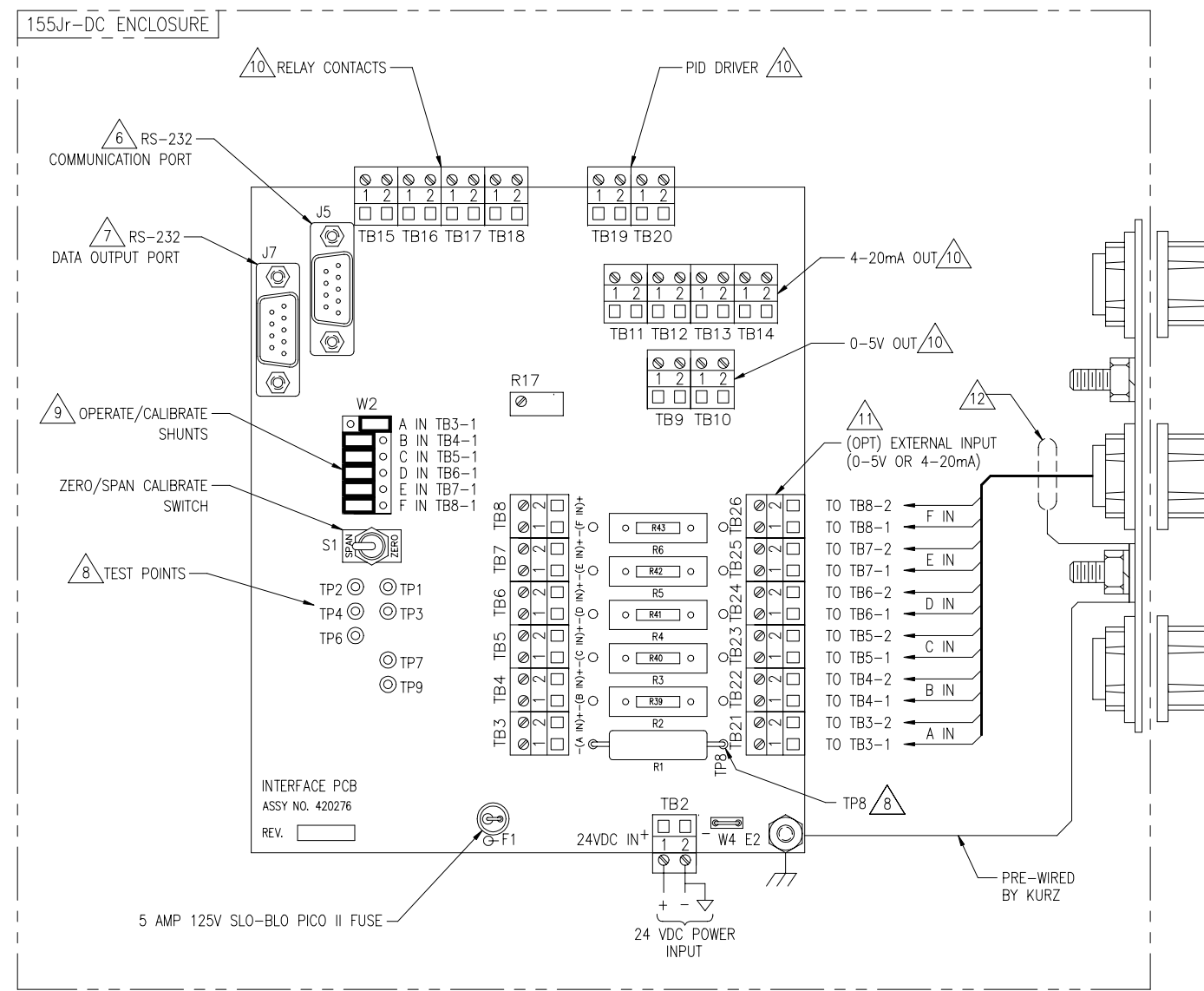

SAMPLE DIAGRAMS, 4-20mA CONNECTIONS

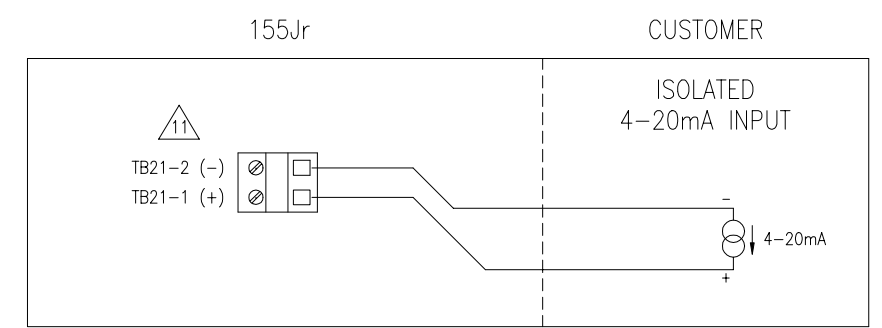
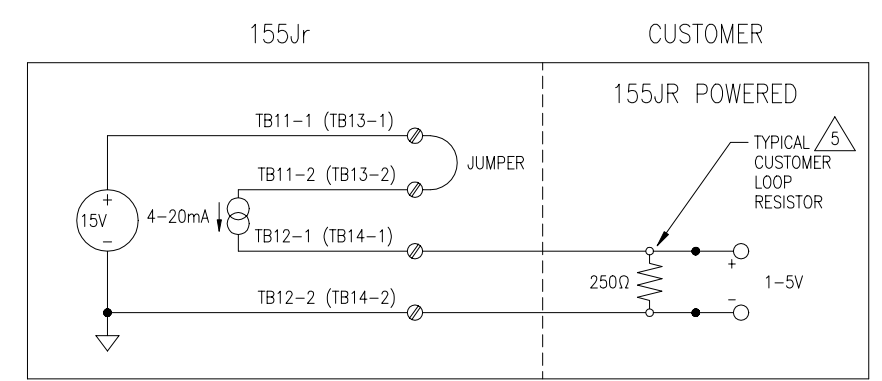
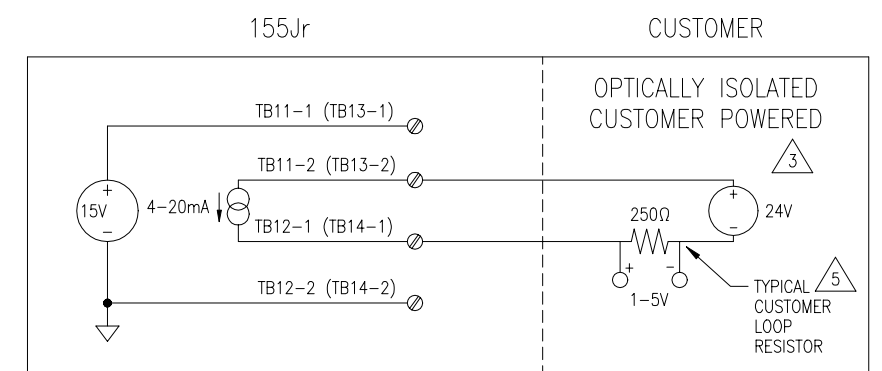

NOTES: UNLESS OTHERWISE SPECIFIED

- THIS WIRING DIAGRAM IS USED IN CONJUNCTION WITH PARENT NUMBERS 750101-DC, 750104-DC, 750105-DC, 750106-DC & 750107-DC.
- REF. DESIGNATORS AND PIN NUMBERS ARE FOR REF. ONLY, AND MAY NOT APPEAR ON COMPONENTS
- 15 TO 50 VDC.
- TB3-1 THRU TB8-1 (INPUTS A THRU F) 0-5 VDC MAX. TB3-2 THRU TB8-2 (OUTPUTS A THRU F) 18 TO 24 VDC.
- MAXIMUM LOOP SERIES RESISTOR VALUE=500 Ω.
- RS-232 COMMUNICATIONS PORT:

J5	PIN	CUSTOMER CONNECT
N/C	1	9 PIN TO 9 PIN
TXD1	2	CABLE, STRAIGHT
RXD1	3	THROUGH
DTR	4	
GND	5	
DSR	6	
RTS	7	
CTS	8	
N/C	9	

- RS-232 DATA OUTPUT PORT:

J7	PIN	CUSTOMER CONNECT
N/C	1	9 PIN TO 9 PIN
TXD0	2	CABLE, STRAIGHT
RXD0	3	THROUGH
DTR	4	
GND	5	
DCDO	6	
RTS0	7	
CTS0	8	
N/C	9	
- TEST POINTS:
 - TP1 +2,500 REF (ADJUST R17)
 - TP2 +5V
 - TP3 -9V
 - TP4 +10V
 - TP6 +12V
 - TP7 +15V
 - TP8 GND REF (LEAD ON R1)
 - TP9 INPUT CAL.
- SHUNT POSITION
 - CHANNEL CALIBRATE
 - OPERATE MODE

- OPTIONAL CONNECTIONS:
 - TB9 - 1 (+) 0-5V } ANALOG OUT 1
 - TB9 - 2 GND } ANALOG OUT 1
 - TB10 - 1 (+) 0-5V } ANALOG OUT 2
 - TB10 - 2 GND } ANALOG OUT 2
 - TB11 - 1 } 4-20mA OUT 1
 - TB11 - 2 } 4-20mA OUT 1
 - TB12 - 1 } 4-20mA OUT 2
 - TB12 - 2 } 4-20mA OUT 2
 - TB13 - 1 } 4-20mA OUT 2
 - TB13 - 2 } 4-20mA OUT 2
 - TB14 - 1 } 4-20mA OUT 2
 - TB14 - 2 } 4-20mA OUT 2
 - TB15 - 1 } ALARM OUT 1
 - TB15 - 2 } ALARM OUT 1
 - TB16 - 1 } ALARM OUT 2
 - TB16 - 2 } ALARM OUT 2
 - TB17 - 1 } ALARM OUT 3
 - TB17 - 2 } ALARM OUT 3
 - TB18 - 1 } ALARM OUT 4
 - TB18 - 2 } ALARM OUT 4
 - TB19 - 1 (+) } PID #1
 - TB19 - 2 (-) } PID #1
 - TB20 - 1 (+) } PID #2
 - TB20 - 2 (-) } PID #2

- OPTIONAL EXTERNAL INPUT (0-5V OR 4-20mA):
 - TB21-1 INPUT A (+ EXT.)
 - TB21-2 INPUT A (- EXT.)
 - TB22-1 INPUT B (+ EXT.)
 - TB22-2 INPUT B (- EXT.)
 - TB23-1 INPUT C (+ EXT.)
 - TB23-2 INPUT C (- EXT.)
 - TB24-1 INPUT D (+ EXT.)
 - TB24-2 INPUT D (- EXT.)
 - TB25-1 INPUT E (+ EXT.)
 - TB25-2 INPUT E (- EXT.)
 - TB26-1 INPUT F (+ EXT.)
 - TB26-2 INPUT F (- EXT.)
- CONNECT INPUT/OUTPUT SHIELDS TO GROUND BUS BAR.
- W4 JUMPER REQUIRED TO CONNECT DC GND TO EARTH GND (E2).

APPROVALS				KURZ INSTRUMENTS, INC.		
DRAWN BY D.F. SINGLETON	DATE 05-11-1995	WIRING DIAGRAM, HOOK-UP, 155 JR-DC		DWG. SIZE D	DWG. NO. 340155-50	REV. D
CHECKED BY T. WILSON	DATE 05-22-1995			SCALE NONE	SHEET 1	OF 1
APPROVED B. BUTTON	DATE 05-22-1995					

155C-2 / E-2 / E-RM2 ENCLOSURE

420306 MOTHERBOARD

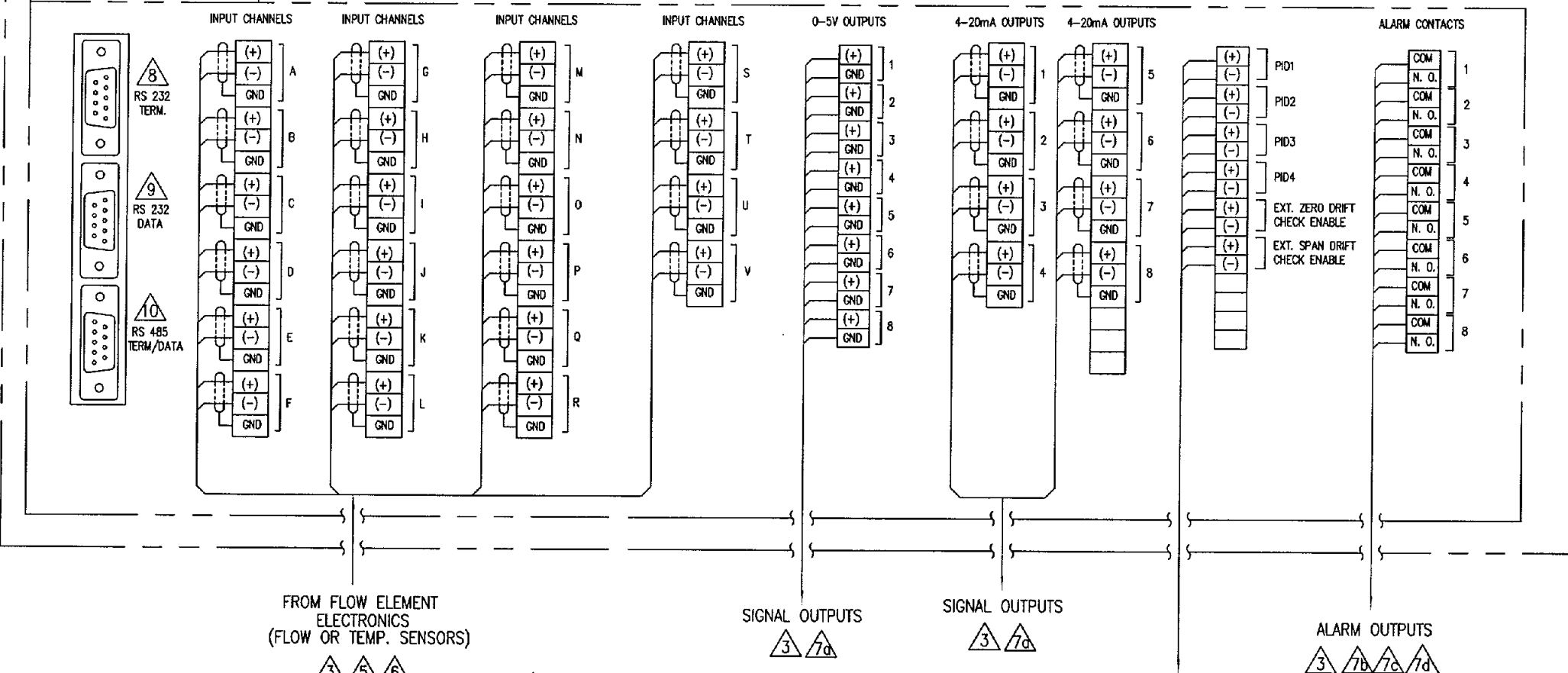

REVISIONS				
REV.	DESCRIPTION	BY	DATE	
D	REDRAWN & REVISED PER ECO# C47265	GF	11-6-07	

NOTES: (FOR SHEET 1 ONLY)

- DRAWING SHOWN WITH MAX. NUMBER OF INPUT/OUTPUT OPTIONS. ACTUAL OPTIONS WILL BE PROVIDED PER CUSTOMER REQUIREMENT. INPUT/OUTPUT CAPABILITY IS DETERMINED BY MAXIMUM SENSOR CURRENT, AMBIENT TEMPERATURE AND AVAILABLE POWER. SEE KURZ BROCHURE "SERIES 155 MASS FLOW COMPUTERS" (DOC NO. 367001).
- REF. DESIGNATORS AND PIN NUMBERS ARE FOR REF. ONLY, AND MAY NOT APPEAR ON COMPONENTS.
- ALL FIELD WIRING CABLES WILL BE PROVIDED AND CONNECTED BY CUSTOMER.
- POWER SUPPLY CORD: 3 CONDUCTORS, 18 AWG RECOMMENDED BELDEN NO. 17407 OR EQUIVALENT.

MODEL	SENSOR SIGNAL	POWER WIRES (+24 VDC & GND RETURN)		
452, 502, ETC. K-BAR-24/-16	2-COND. W/ SHIELD ONE PER SENSOR	N/A		
			WIRE GA.	LENGTH ONE WAY, FT./(M)
			18	260 / (80)
			16	410 / (132)
454, 504, ETC. K-BAR-2000	24 AWG COND. OR LARGER, TWO PER SENSOR, ONE FOR FLOW, ONE FOR TEMP.	WIRE GA.	LENGTH ONE WAY, FT./(M)	
			18	130 / (40)
			16	205 / (62)
			14	330 / (101)
SERIES MFT AND MFTB PRODUCT LINES		WIRE GA.	LENGTH ONE WAY, FT./(M)	
			12	520 / (158)

LABEL	DESCRIPTION
"+"	+24 VDC, 4A PTC LIMITED
"-"	INPUT, 250 OHM OR 5 OHM LOAD RESISTOR, 0-5 VDC MAX.
GND	CHASSIS GND

7. CABLES RECOMMENDED FOR OUTPUT OPTIONS:
- 0-5 VDC AND 4-20 mA: USE TWO CONDUCTOR CABLE, 18-24 AWG, ONE PER OUTPUT.
 - RELAY CONTACT OUTPUTS: USE TWO CONDUCTOR CABLE, ONE PER OUTPUT. USE 18 AWG FOR MAXIMUM 5A CONTACTS; SMALLER WIRE GAGE IS ALLOWABLE FOR LOWER CURRENT.
 - ALARM MODE IS SET BY SOFTWARE. CONTACTS ARE SET TO NORMALLY OPEN (NO) UNLESS OTHERWISE SPECIFIED BY CUSTOMER.
 - CHANNEL KICKOUT ALARM IS ALWAYS THE LAST ALARM ENABLED IN THE CONFIGURATION.

DESC.	PIN
N/C	1
TXD1	2
RXD1	3
DTR	4
GND	5
DSR	6
RTS	7
CTS	8

PID 1 TO 4 FOR UP TO (4) KURZ SERIES 731 FLOW CONTROL VALVES CONTACT CLOSURE FOR ZERO DRIFT & CHECK CONTACT CLOSURE FOR SPAN DRIFT & CHECK

DESC.	PIN
N/C	1
TXD0	2
RXD0	3
DTR	4
GND	5
DCD0	6
RTS0	7
CTS0	8
N/C	9

DESC.	PIN
TERM. TRANSMIT +	1
TERM. TRANSMIT -	2
TERM. RECEIVE +	3
TERM. RECEIVE -	4
GND	5
DATA TRANSMIT +	6
DATA TRANSMIT -	7
DATA RECEIVE +	8
DATA RECEIVE -	9

UNLESS OTHERWISE SPECIFIED DIMENSIONS ARE IN INCHES		APPROVALS		KURZ INSTRUMENTS, INC.
TOLERANCES ARE		DRAWN BY	DATE	
FRACTIONS	± 1/16	G. FOSTER	11/6/07	MODEL 155C-2/E-2/E-RM2
ANGLES	± 1°-0'	DATE		
DECIMALS		APPROVED	DATE	FIELD WIRING
.XX	± 0.1			
.XXX	± 0.03			DWG. NO. 340155-55
ORIG. RELEASE DATE				SCALE NONE
NEXT ASSEMBLY				SHEET 1/2

THIS INSTRUMENT AND COMPONENTS THEREOF ARE COVERED BY THE PATENT RIGHTS OF KURZ INSTRUMENTS, INC. NO PART OF THIS INSTRUMENT OR COMPONENTS THEREOF SHALL BE REPRODUCED OR TRANSMITTED IN ANY FORM OR BY ANY MEANS, ELECTRONIC OR MECHANICAL, INCLUDING PHOTOCOPYING, RECORDING, OR BY ANY INFORMATION STORAGE AND RETRIEVAL SYSTEM, WITHOUT PERMISSION IN WRITING BY KURZ INSTRUMENTS, INC.

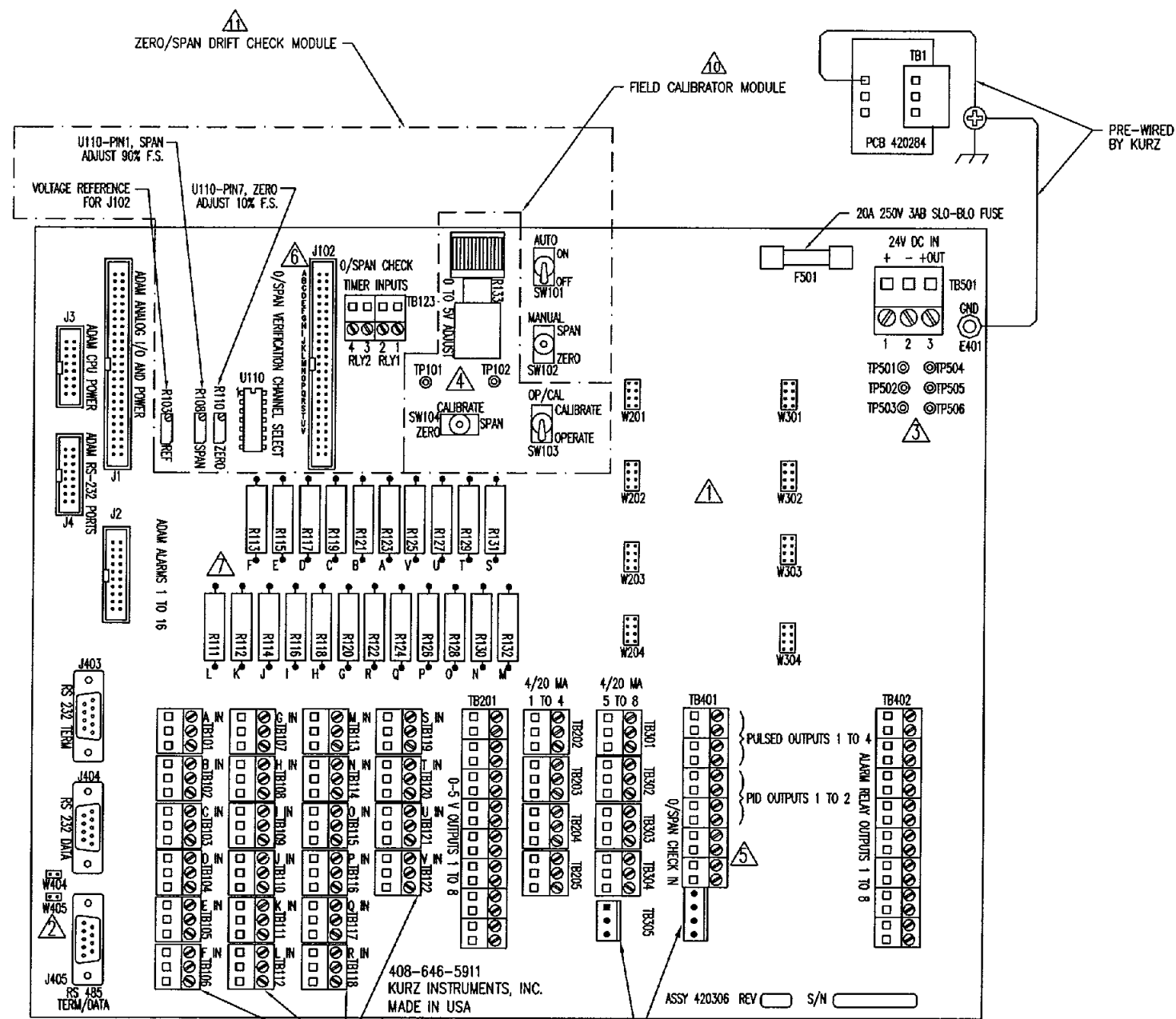

408-646-5911
 KURZ INSTRUMENTS, INC.
 MADE IN USA
 ASSY 420306 REV S/N

SAMPLE 4-20 mA OUTPUT CONNECTIONS

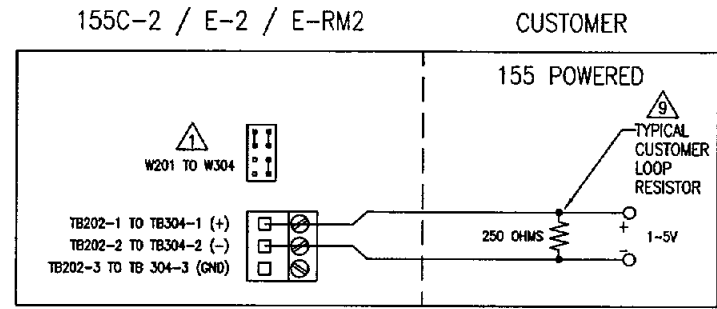
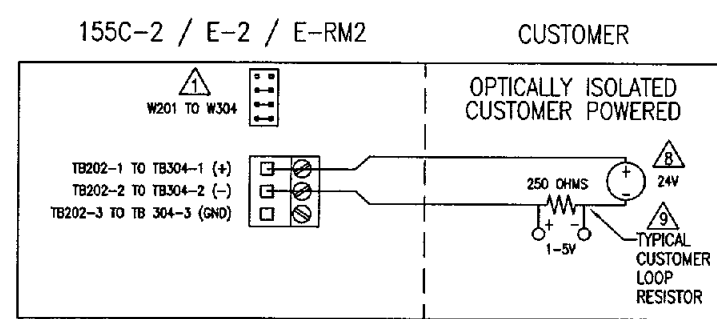

SAMPLE 4-20 mA INPUT CONNECTIONS

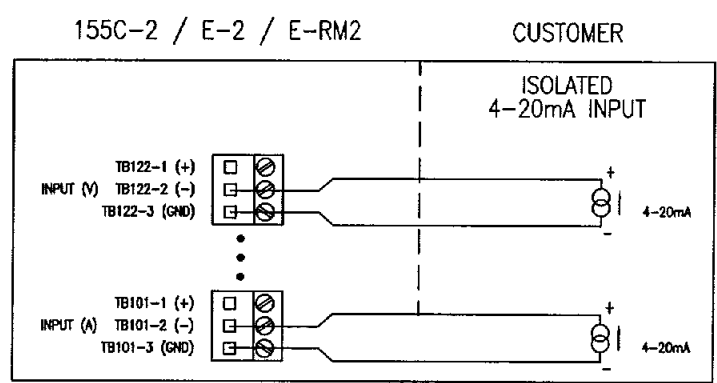

NOTES : (FOR SHEET 2 ONLY).

⚠ JUMPERS CORRESPOND TO TERMINALS AS SHOWN BELOW

OUTPUT	TERMINAL	JUMPER
1	TB202	W201
2	TB203	W202
3	TB204	W203
4	TB205	W204
5	TB301	W301
6	TB302	W302
7	TB303	W303
8	TB304	W304

⚠ W404-W405, TERMINAL AND DATA PORT EXT. COMMUNICATIONS
 RS 232 RS 485 (OPT)
 W404 W405

⚡ TP501 +24V
 TP502 +12V
 TP503 +5V REF
 TP504 GND
 TP505 +5V
 TP506 -9V

⚡ TP101 (GND) AND TP102 (+), CALIBRATION TEST POINTS FOR 0 TO 5 V ADJUST.

⚡ EXT. ZERO/SPAN CHECK INPUTS
 TB401-9 ZERO CONTACT POLE
 TB401-10 ZERO DC GROUND
 TB401-11 SPAN CONTACT POLE
 TB401-12 SPAN DC GROUND

⚡ SHUNT CHANNEL TO VERIFY-SEE SERIES 155 MASS FLOW COMPUTER SUMMARY GUIDE (DOC# 380204-x-xx)

⚡ CURRENT SENSE RESISTOR VALUES ARE SELECTED.

⚡ 15 TO 50 VDC.

⚡ MAXIMUM LOOP SERIES RESISTOR VALUE=500 OHMS.

⚡ OP/CAL SWITCH MUST BE IN 'OPERATE' POSITION FOR NORMAL OPERATION. SEE "SERIES 155 MASS FLOW COMPUTER/TRANSMITTER USER'S GUIDE" (DOC NO. 360147) FOR OPERATION OF FIELD CALIBRATOR MODULE AND ZERO/SPAN DRIFT CHECK MODULE.

⚡ TB123- ZERO/SPAN DRIFT CHECK TIMER CONNECTOR FOR "AUTO" MODE
 TB123-1 ZERO GROUND CONTACT
 TB123-2 ZERO ENABLE CONTACT
 TB123-3 SPAN GROUND CONTACT
 TB123-4 SPAN ENABLE CONTACT

INPUT CONNECTIONS

⚡ TB101-1 +24 VDC
 TB101-2 INPUT
 TB101-3 GND } INPUT CHANNEL (A)
 ⚡ TB102-1 +24 VDC
 TB102-2 INPUT
 TB102-3 GND } INPUT CHANNEL (B)

INPUT CONNECTIONS (CONT.)

⚡ TB103-1 +24 VDC
 TB103-2 INPUT
 TB103-3 GND } INPUT CHANNEL (C)
 ⚡ TB104-1 +24 VDC
 TB104-2 INPUT
 TB104-3 GND } INPUT CHANNEL (D)
 ⚡ TB105-1 +24 VDC
 TB105-2 INPUT
 TB105-3 GND } INPUT CHANNEL (E)
 ⚡ TB106-1 +24 VDC
 TB106-2 INPUT
 TB106-3 GND } INPUT CHANNEL (F)
 ⚡ TB107-1 +24 VDC
 TB107-2 INPUT
 TB107-3 GND } INPUT CHANNEL (G)
 ⚡ TB108-1 +24 VDC
 TB108-2 INPUT
 TB108-3 GND } INPUT CHANNEL (H)

⚡ TB109-1 +24 VDC
 TB109-2 INPUT
 TB109-3 GND } INPUT CHANNEL (I)
 ⚡ TB110-1 +24 VDC
 TB110-2 INPUT
 TB110-3 GND } INPUT CHANNEL (J)
 ⚡ TB111-1 +24 VDC
 TB111-2 INPUT
 TB111-3 GND } INPUT CHANNEL (K)
 ⚡ TB112-1 +24 VDC
 TB112-2 INPUT
 TB112-3 GND } INPUT CHANNEL (L)
 ⚡ TB113-1 +24 VDC
 TB113-2 INPUT
 TB113-3 GND } INPUT CHANNEL (M)
 ⚡ TB114-1 +24 VDC
 TB114-2 INPUT
 TB114-3 GND } INPUT CHANNEL (N)

⚡ TB115-1 +24 VDC
 TB115-2 INPUT
 TB115-3 GND } INPUT CHANNEL (O)
 ⚡ TB116-1 +24 VDC
 TB116-2 INPUT
 TB116-3 GND } INPUT CHANNEL (P)
 ⚡ TB117-1 +24 VDC
 TB117-2 INPUT
 TB117-3 GND } INPUT CHANNEL (Q)
 ⚡ TB118-1 +24 VDC
 TB118-2 INPUT
 TB118-3 GND } INPUT CHANNEL (R)
 ⚡ TB119-1 +24 VDC
 TB119-2 INPUT
 TB119-3 GND } INPUT CHANNEL (S)
 ⚡ TB120-1 +24 VDC
 TB120-2 INPUT
 TB120-3 GND } INPUT CHANNEL (T)

⚡ TB121-1 +24 VDC
 TB121-2 INPUT
 TB121-3 GND } INPUT CHANNEL (U)
 ⚡ TB122-1 +24 VDC
 TB122-2 INPUT
 TB122-3 GND } INPUT CHANNEL (V)

KURZ INSTRUMENTS, INC.
 MODEL 155C-2/E-2/E-RM2
 FIELD WIRING

DWG. SIZE	DWG. NO.	REV.
D	340155-55	D
SCALE	NONE	SHEET 2/2

155C-2 / E-2 / E-RM2 ENCLOSURE

420306 MOTHERBOARD

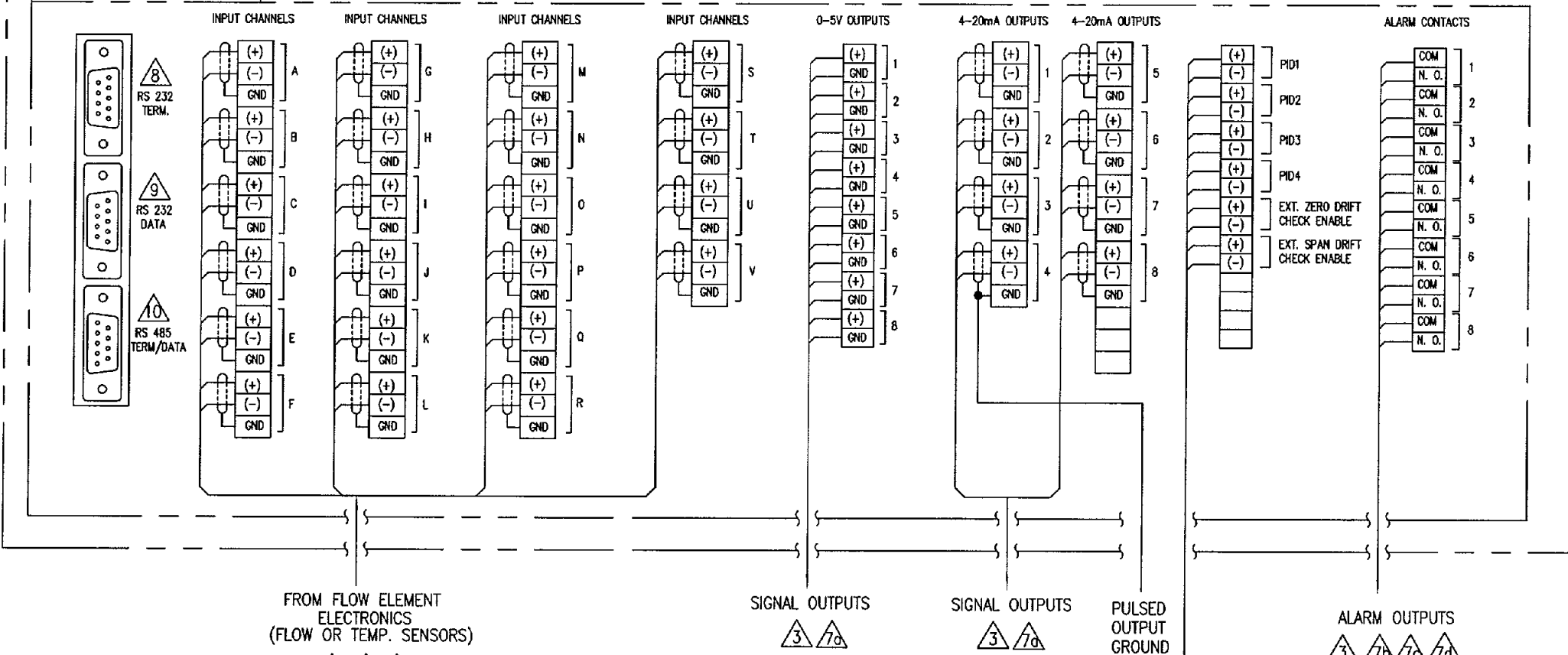

REVISIONS					
REV.	DESCRIPTION	BY	CHKD	APPROD	DATE
C	REDRAWN & REVISED PER ECO# C47265	GF	11/6/07	11/6/07	11-6-07

TABLE 1
OUTPUT TO ALARM MAPPING

OUTPUT	ALARM
PULSED OUTPUT 1	9
PULSED OUTPUT 2	10
PULSED OUTPUT 3	11
PULSED OUTPUT 4	12
PID OUTPUT 1 ENABLE	13
PID OUTPUT 1 DIRECTION	14
PID OUTPUT 2 ENABLE	15
PID OUTPUT 2 DIRECTION	16

NOTES: (FOR SHEET 1 ONLY)

1. DRAWING SHOWN WITH MAX. NUMBER OF INPUT/OUTPUT OPTIONS. ACTUAL OPTIONS WILL BE PROVIDED PER CUSTOMER REQUIREMENT. INPUT/OUTPUT CAPABILITY IS DETERMINED BY MAXIMUM SENSOR CURRENT, AMBIENT TEMPERATURE AND AVAILABLE POWER. SEE KURZ BROCHURE "SERIES 155 MASS FLOW COMPUTERS" (DOC NO. 367001).

2. REF. DESIGNATORS AND PIN NUMBERS ARE FOR REF. ONLY, AND MAY NOT APPEAR ON COMPONENTS.

3. ALL FIELD WIRING CABLES WILL BE PROVIDED AND CONNECTED BY CUSTOMER.

4. POWER SUPPLY CORD: 3 CONDUCTORS, 18 AWG RECOMMENDED BELDEN NO. 17407 OR EQUIVALENT.

5. CABLE RECOMMENDATIONS FOR SENSOR CONNECTIONS

MODEL	SENSOR SIGNAL	POWER WIRES (+24 VDC & GND RETURN)	
452, 502, ETC. K-BAR-24/-16	2-COND. W/ SHIELD ONE PER SENSOR	N/A	
		WIRE GA.	LENGTH ONE WAY, FT./(M)
		18	260 / (80)
		16	410 / (132)
454, 504, ETC. K-BAR-2000 SERIES MFT AND MFTB PRODUCT LINES	24 AWG COND. OR LARGER, TWO PER SENSOR, ONE FOR FLOW, ONE FOR TEMP.	WIRE GA.	LENGTH ONE WAY, FT./(M) (4 SENSOR K-BAR-2000 LOAD ASSUMED)
		18	130 / (40)
		16	205 / (62)
		14	330 / (101)
12	520 / (158)		

6. INPUT CHANNEL DESCRIPTION

LABEL	DESCRIPTION
"+"	+24 VDC, 4A PTC LIMITED
"-"	INPUT, 250 OHM OR 5 OHM
	LOAD RESISTOR, 0-5 VDC MAX.
GND	CHASSIS GND

7. CABLES RECOMMENDED FOR OUTPUT OPTIONS:

- a) 0-5 VDC AND 4-20 mA: USE TWO CONDUCTOR CABLE, 18-24 AWG, ONE PER OUTPUT.
- b) RELAY CONTACT OUTPUTS: USE TWO CONDUCTOR CABLE, ONE PER OUTPUT. USE 18 AWG FOR MAXIMUM 5A CONTACTS; SMALLER WIRE GAGE IS ALLOWABLE FOR LOWER CURRENT.
- c) ALARM MODE IS SET BY SOFTWARE (SEE TABLE 1). CONTACTS ARE SET TONORMALLY OPEN (NO) UNLESS OTHERWISE SPECIFIED BY CUSTOMER.
- d) CHANNEL KICKOUT ALARM IS ALWAYS THE LAST ALARM ENABLED IN THE CONFIGURATION.

8. RS-232 TERMINAL PORT (J403, DB-9 MALE). CUSTOMER CONNECT 9 PIN TO 9 PIN CABLE STRAIGHT THROUGH.

DESC.	PIN
N/C	1
TXD1	2
RXD1	3
DTR	4
GND	5
DSR	6
RTS	7
CTS	8

PID 1 & 2 FOR (4) PULSED OUTPUTS
731 FLOW CONTROL VALVES
PID 3 & 4 FOR (2) KURZ SERIES
731 FLOW CONTROL VALVES
CONTACT CLOSURE FOR ZERO DRIFT & CHECK
CONTACT CLOSURE FOR SPAN DRIFT & CHECK

9. RS-232 DATA PORT (J404, DB-9 MALE). CUSTOMER CONNECT 9 PIN TO 9 PIN CABLE STRAIGHT THROUGH.

DESC.	PIN
N/C	1
TXD0	2
RXD0	3
DTR	4
GND	5
DCD0	6
RTS0	7
CTS0	8
N/C	9

10. RS-485 TERM./DATA PORT (J405, DB-9 FEMALE).

DESC.	PIN
TERM. TRANSMIT +	1
TERM. TRANSMIT -	2
TERM. RECEIVE +	3
TERM. RECEIVE -	4
GND	5
DATA TRANSMIT +	6
DATA TRANSMIT -	7
DATA RECEIVE +	8
DATA RECEIVE -	9

UNLESS OTHERWISE SPECIFIED DIMENSIONS ARE IN INCHES		APPROVALS		KURZ INSTRUMENTS, INC.
TOLERANCES ARE		DRAWN BY	DATE	
FRACTIONS	± 1/16	G.FOSTER	11/6/07	MODEL 155C-2/E-2/E-RM2 FIELD WIRING W/ PULSED OUTPUTS
ANGLES	± 1°-0'	CHECKED BY	DATE	
DECIMALS		APPROVED	DATE	DWG. NO. 340155-57
.X	± 0.1			REV. C
.XX	± 0.03			DWG. SIZE D
.XXX	± 0.003			SCALE NONE
ORIG. RELEASE DATE				SHEET 1/2

Appendix D

State Menu Diagrams

340155-26 KAS Menu State diagram (five sheets)

REVISIONS					
REV.	DESCRIPTION	BY	CHKD	APRVD	DATE
F	PER ECO #B47601	KB	TW	TW	4/13/99

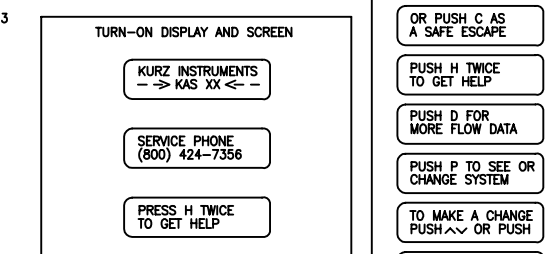
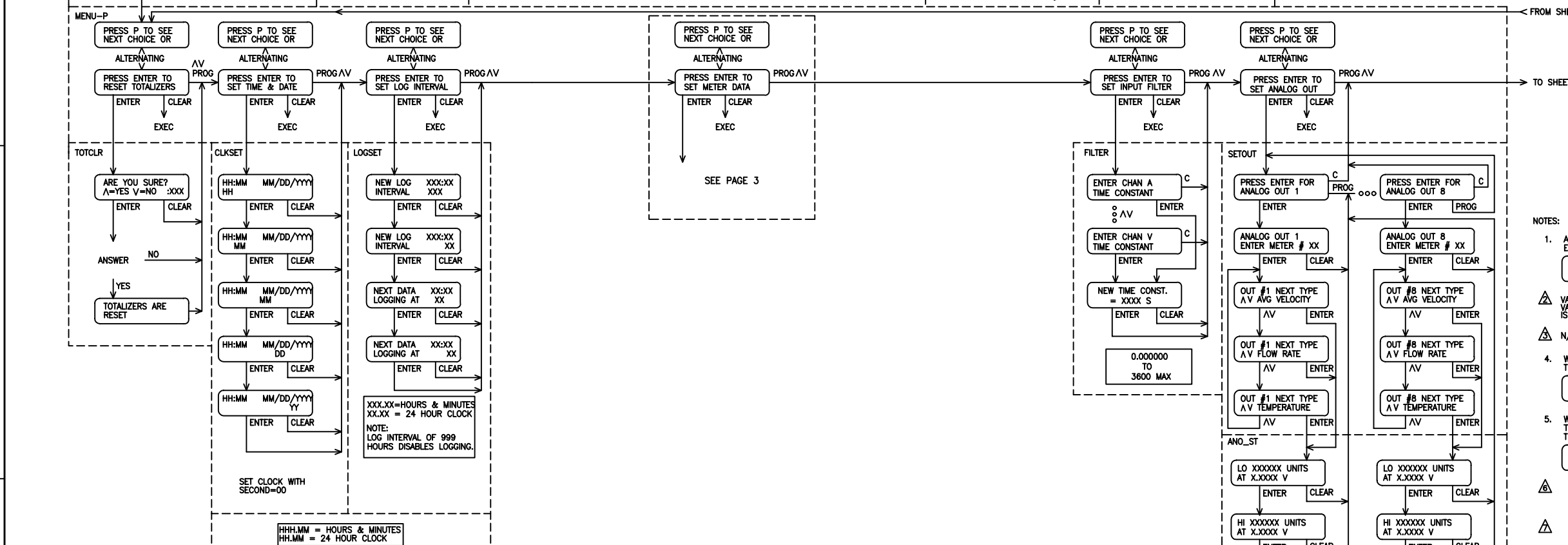
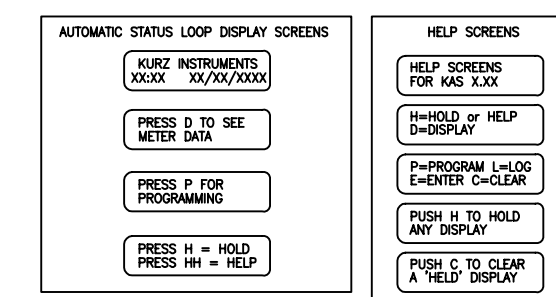
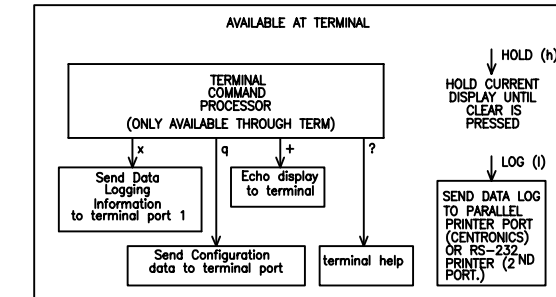
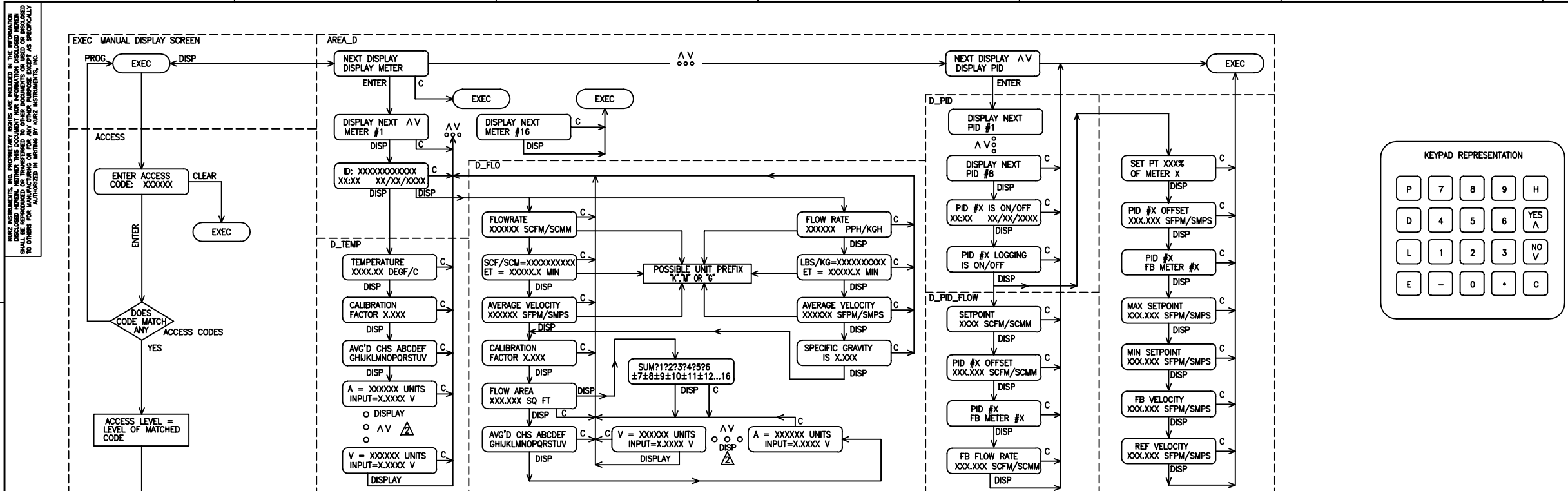

- NOTES:
- AFTER NEW VALUE IS ENTERED SCREEN SHOWS: NEW VALUE ACCEPTED
 - VALUES OF UNITS ARE ORIGINAL CALIBRATED VALUES FROM LINEARIZER TABLES BEFORE C.F. IS APPLIED (E V/N).
 - N/A
 - WHEN H IS PRESSED THE SCREEN SHOWS: HOLD IS ACTIVATED
 - WHEN C IS PRESSED TO CLEAR A HOLD THE SCREEN SHOWS: HOLD IS CLEARED
 - CHANNEL KICKOUT MUST BE TURNED ON FOR THIS FEATURE TO WORK.
 - MAXIMUM OF FOUR DATA SETS POSSIBLE.
 - MAXIMUM OF THREE TEMP DATA SETS POSSIBLE.
 - MAXIMUM OF SEVEN DATA POINTS POSSIBLE.

ADAM SOFTWARE
KAS 6.81 4-2-98
UPDN V6.81 7-28-98

SHEET #5 IS FOR FACTORY USE ONLY AND REQUIRES FACTORY ACCESS CODE.

UNLESS OTHERWISE SPECIFIED DIMENSIONS ARE IN INCHES		APPROVALS		KURZ INSTRUMENTS, INC.	
TOLERANCES ARE		DRAWN BY	DATE	SERIES 155 MASS FLOW COMPUTERS	
FRACTIONS ± 1/16		KEN B	4-6-99	STATE DIAGRAM FOR KAS 6.81	
ANGLES ± 1°-0'		CHECKED BY	DATE	DWG. SIZE	DWG. NO. 34015526
DECIMALS		T.WILSON	4-13-99	D	SCALE
.X ± 0.1		APPROVED	DATE	REV. F	SHEET 1 OF 5
.XX ± 0.03		T.WILSON	4-13-99		
.XXX ± 0.003					
ORIG. RELEASE DATE					

ADAM INSTRUMENTS, INC. PROPRIETARY RIGHTS ARE INCLUDED IN THE INFORMATION CONTAINED HEREIN. NO PART OF THIS DOCUMENT OR INFORMATION DISCLOSED HEREIN SHALL BE REPRODUCED OR TRANSMITTED IN ANY FORM OR BY ANY MEANS, ELECTRONIC OR MECHANICAL, INCLUDING PHOTOCOPYING, RECORDING, OR BY ANY INFORMATION STORAGE AND RETRIEVAL SYSTEM, WITHOUT PERMISSION IN WRITING BY ADAM INSTRUMENTS, INC.

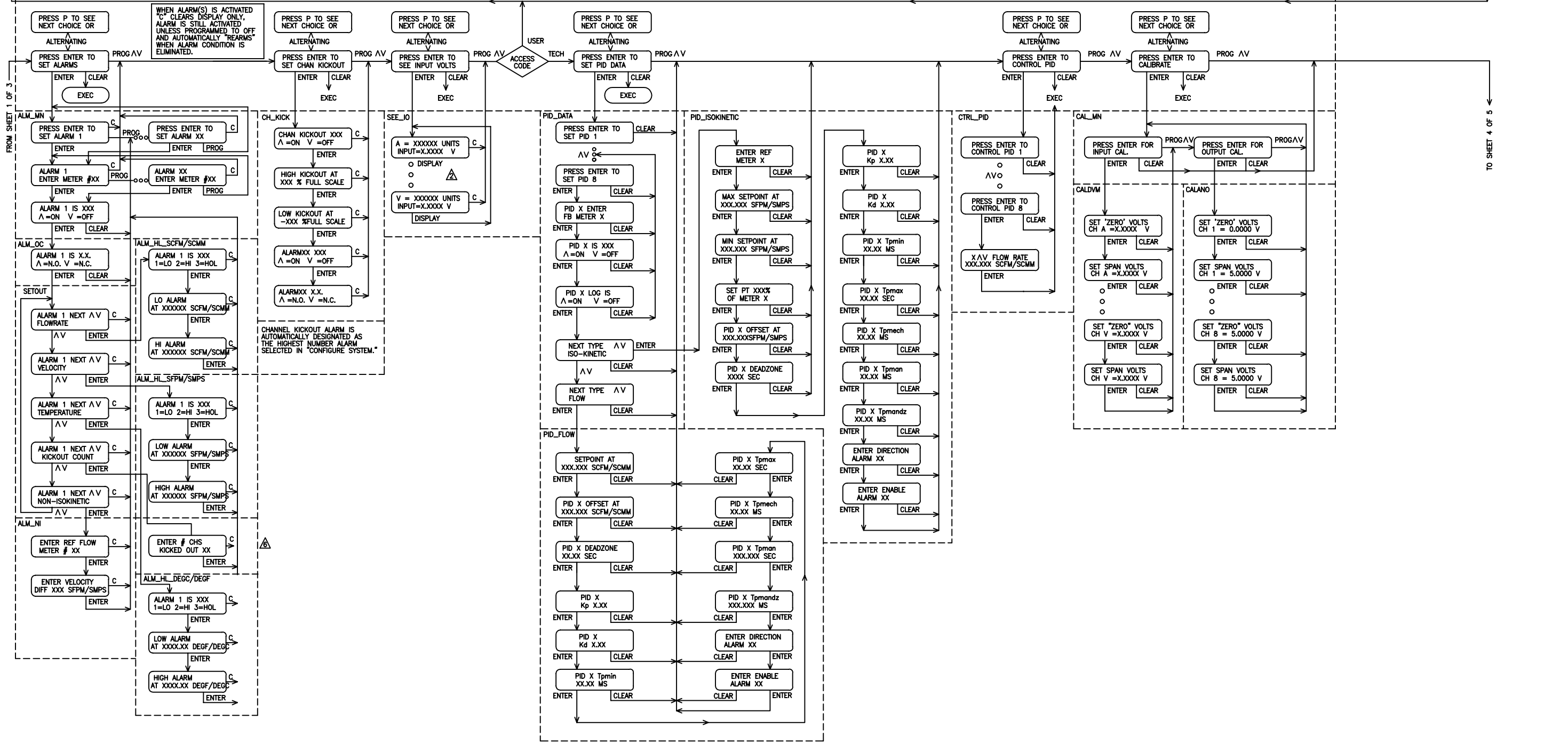

TO SHEET 1 OF 3

FROM SHEET 4 OF 5

FROM SHEET 1 OF 3

TO SHEET 4 OF 5

ADAM SOFTWARE
KAS 6.81 4-2-98
UPDN V6.81 7-28-98

SHEET #5 IS FOR FACTORY USE ONLY
AND REQUIRES FACTORY ACCESS CODE.

DWG. SIZE	DWG. NO. 340155-26	REV. F
SCALE NONE	SHEET 2 OF 5	

KAS INSTRUMENTS, INC. PROPRIETARY RIGHTS ARE INCLUDED IN THE INFORMATION CONTAINED HEREIN. NO PART OF THIS DOCUMENT OR INFORMATION DISCLOSED HEREIN SHALL BE REPRODUCED, COPIED, TRANSMITTED, OR IN ANY MANNER MADE AVAILABLE TO OTHERS FOR MANUFACTURING OR FOR ANY OTHER PURPOSE EXCEPT AS SPECIFICALLY AUTHORIZED IN WRITING BY KAS INSTRUMENTS, INC.

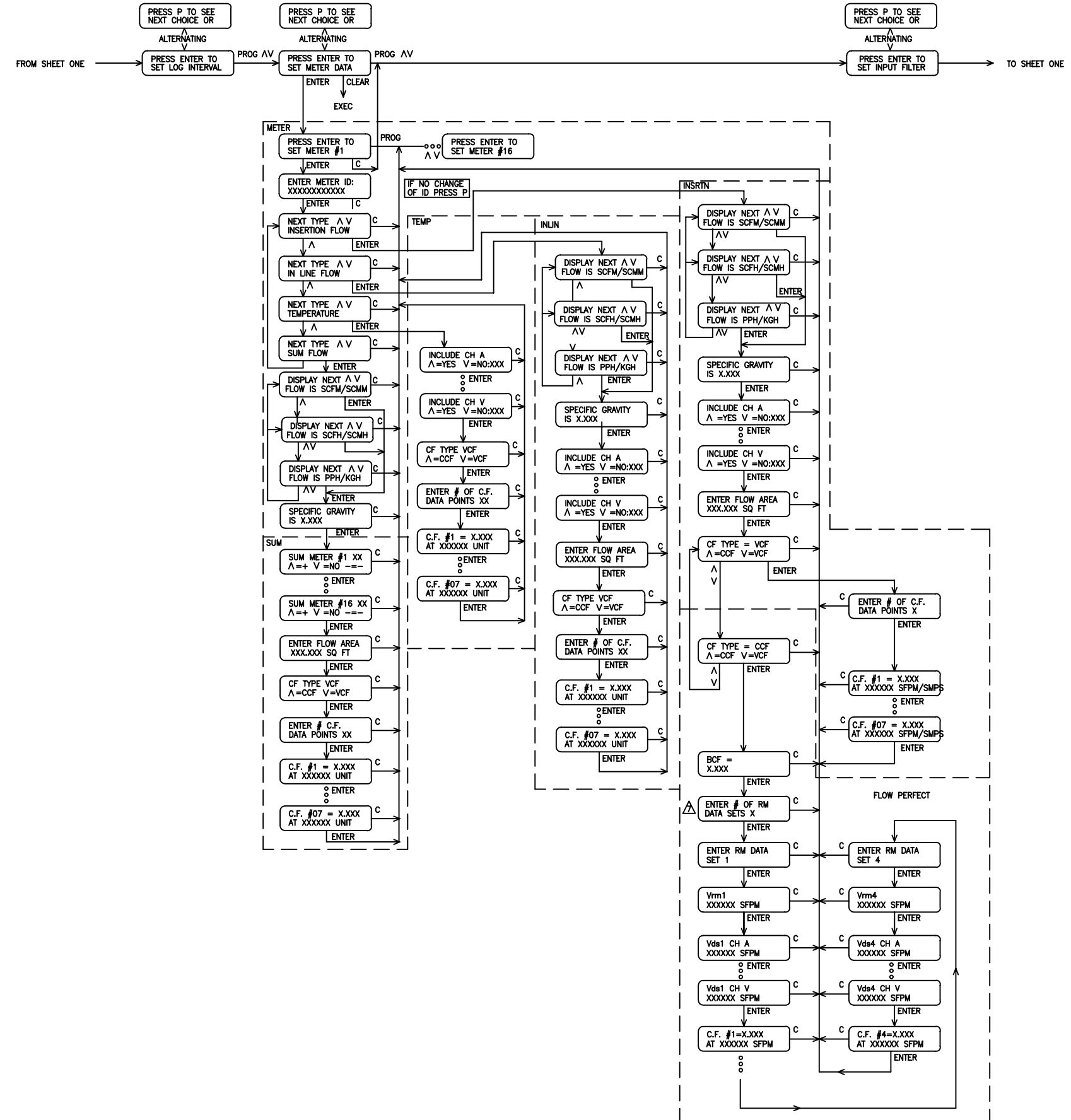

ADAM SOFTWARE
KAS 6.81 4-2-98
UPDN V6.81 7-28-98

SHEET #5 IS FOR FACTORY USE ONLY
AND REQUIRES FACTORY ACCESS CODE.

DWG. SIZE D	DWG. NO. 340155-26	REV. F
SCALE NONE	SHEET 3 OF 5	

D

C

B

A

KULZE INSTRUMENTS, INC. PROPRIETARY RIGHTS ARE INCLUDED IN THE INFORMATION
 DISCLOSED HEREIN. WHETHER THIS DOCUMENT AND INFORMATION DISCLOSED HEREIN
 IS A TRADE SECRET OR NOT, IT IS HEREBY DECLARED TO BE A TRADE SECRET AND
 IS TO BE KEPT SECRET AND NOT DISCLOSED TO ANY OTHER PERSON OR ENTITY
 WITHOUT THE WRITTEN AUTHORIZATION OF KULZE INSTRUMENTS, INC.

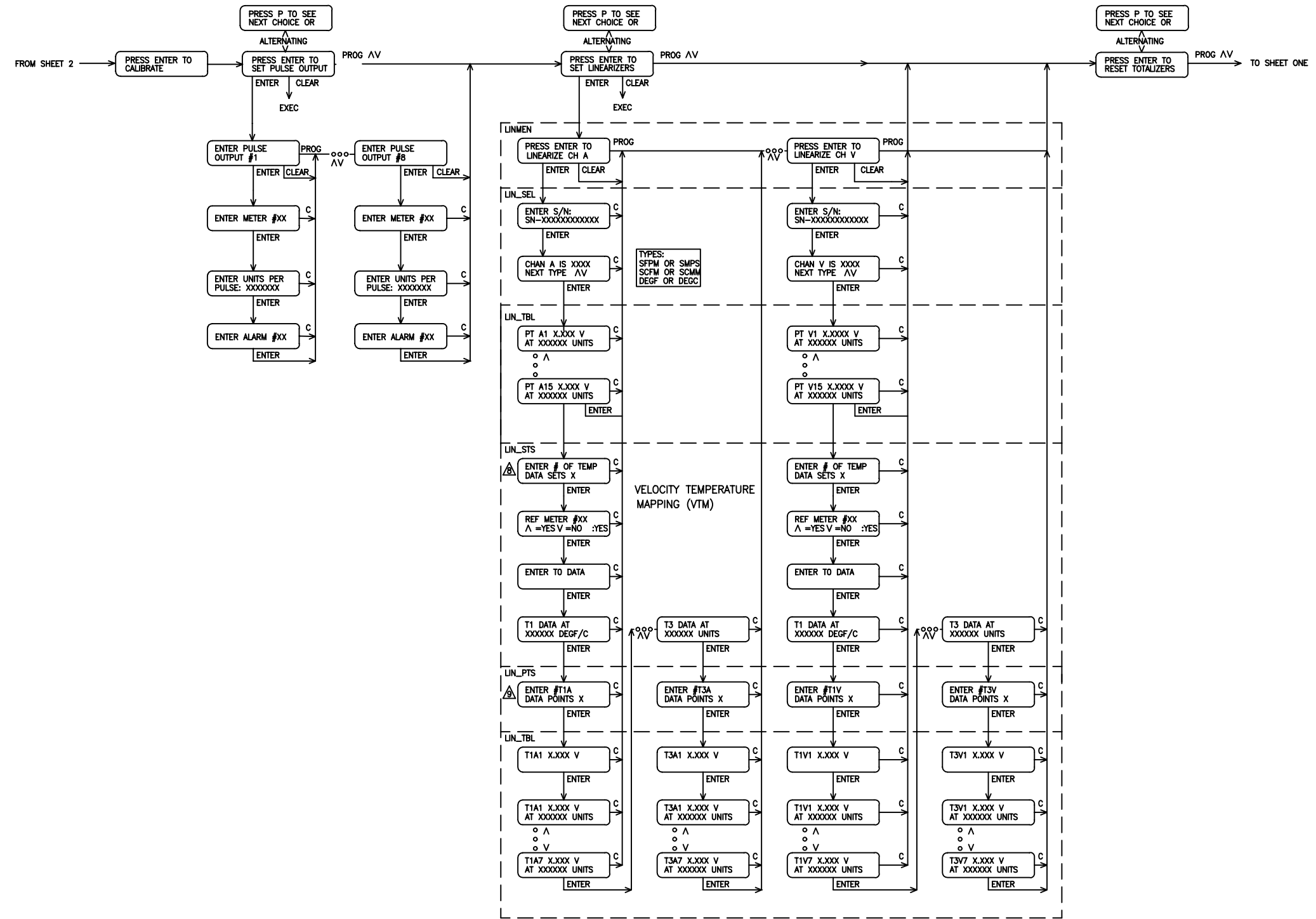

D

C

B

A

ADAM SOFTWARE
 KAS 6.81 4-2-98
 UPDN V6.81 7-28-98

SHEET #5 IS FOR FACTORY USE ONLY
 AND REQUIRES FACTORY ACCESS CODE.

DWG. SIZE	DWG. NO. 340155-26	REV. P
SCALE NONE	SHEET 4 OF 5	

KAS INSTRUMENTS, INC. PROPRIETARY RIGHTS ARE INCLUDED IN THE INFORMATION CONTAINED HEREIN. THIS DOCUMENT AND INFORMATION DISCLOSED HEREIN SHALL BE KEPT CONFIDENTIAL AND NOT BE REPRODUCED OR TRANSMITTED IN ANY FORM OR BY ANY MEANS, ELECTRONIC OR MECHANICAL, INCLUDING PHOTOCOPYING, RECORDING, OR BY ANY INFORMATION STORAGE AND RETRIEVAL SYSTEM, WITHOUT THE WRITTEN PERMISSION OF KAS INSTRUMENTS, INC.

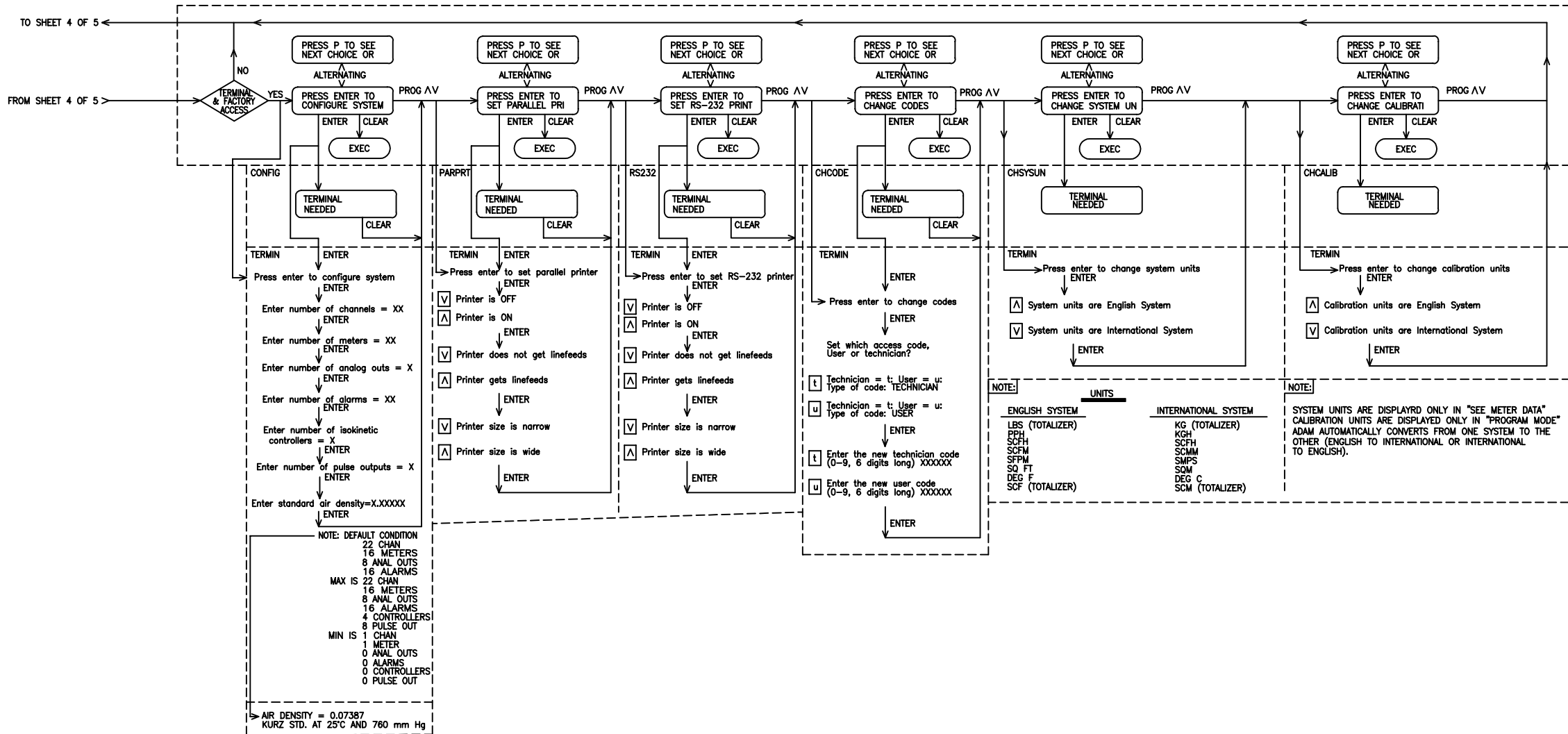

FOR INTERNAL USE ONLY

ADAM SOFTWARE
KAS 6.81 4-2-98
UPDN V6.81 7-28-98

SHEET #5 IS FOR FACTORY USE ONLY AND REQUIRES FACTORY ACCESS CODE.

DWG. SIZE	DWG. NO. 340155-26	REV. F
D	SCALE NONE	SHEET 5 OF 5