

# K-BAR 2000B

## MULTI-POINT INSERTION MASS FLOW ELEMENTS

inlines



Fps

**INTRODUCTION**

Since the introduction in 1984, the K-BAR has become a recognized standard for measuring mass flow rates in larger ducts or stacks that have non-uniform velocity profiles, high turn-down ratios, dirty gas streams, wide temperature ranges and fast velocity and temperature changes. Major applications are for combustion air flow measurement and stack mass flow measurement for continuous emissions monitoring (Kurz satisfies all requirements of U.S. EPA 40 CFR 75, CEM stack flow monitors). One or more K-BARs, combined with one of the Series 155 "ADAM" Mass Flow Computer comprise a "SMART" Multi-Point Insertion Mass Flow Meter. Rugged, reliable, dirt insensitive with hundreds of successful heavy-duty industrial installations, Kurz "SMART" Mass Flow Meters outperform conventional pneumatic and ultrasonic meters when accuracy, repeatability, ease-of-installation, simplicity, and overall costs are considered. For dirty applications, such as power plants, Kurz offers the K-BAR 2000BP with an Optional Purge Air Sensor Cleaning System.

The K-BAR 2000B incorporates the newest Kurz thermal convection mass flow technology (MFTB). This includes a fast, powerful microprocessor and patented digital bridge circuit that measures both the gas velocity and the gas temperature using only the two sensor elements on the "FD2" Fast Dual MetalClad™ sensor.

**PRINCIPLE OF OPERATION**

One or more K-BARs, each having one or more mass velocity sensors positioned at equal area locations in the duct/stack measure the instantaneous average mass velocity and temperature. The Series 155 "SMART" Mass Flow Computer converts the independent velocity and temperature inputs to mass flow rate and average temperature, as well as displays and outputs all the information.

The K-BAR 2000B features the unique "MetalClad" "FD2" Fast Dual MetalClad™ thermal mass flow sensor (see Fig. 1). Kurz sensors provide the fastest velocity and temperature response available (see Fig. 2 and Fig. 3). The Kurz "FD2" sensor can tolerate yaw and rotational velocity deviations of ±20 degrees with less than a ±2% error (see Fig. 4).

**APPLICATIONS**

- EPA Clean Air Act Stack Mass Flow Monitor
- Boiler, Primary, Secondary and Tertiary Combustion Air Flow for efficiency and NO<sub>x</sub> control
- Coal Pulverizer Air Flow
- Municipal Waste Incinerators
- Flare Gas Metering
- High Temperature Air Flows having highly non-uniform temperature and velocity profiles.
- Recovery Boilers

**KEY FEATURES**

- Exceptional accuracy and repeatability (.25% 0 to 12,000 SFPM)
- High temperature (260°C and 500°C)
- Simultaneous temperature and mass velocity measurements at each sensor location
- Exceptional accuracy over wide ranging temperatures and mass velocity using VTM
- Insensitive to dirty and corrosive gases
- All-welded construction
- Pressure and temperature compensated
- Optional Air Purge Sensor Cleaning System
- Simple, low cost installation
- All-welded Alloy C-276 sensor material
- Fast response to velocity and temperature changes
- Attitude insensitive, lead length independent
- New digital sensor control
- Specified accuracy over a 500°C temperature range
- RFI, EMI and Lightning protection
- EMI Approval with CE Compliance
- Non-Incendive Safety Rating

**Figure 1**  
Fast Dual (FD2) Sensor in K-BAR 2000B.



**Fig. 2**  
Sensor Response to a change in Velocity at 6000 SFPM.

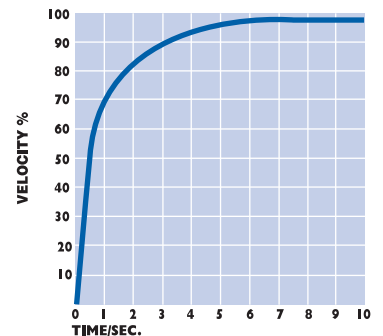

**Fig. 3**  
Sensor Response to a change in Temperature at Constant Velocity.

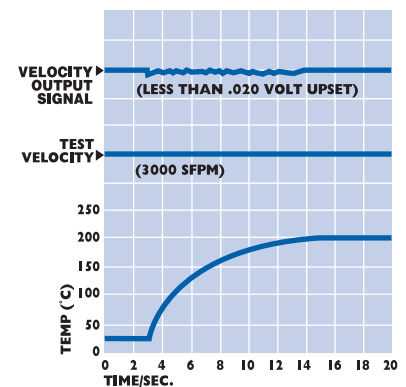

**Fig. 4**  
Sensor Rotation/Yaw Measurement Error.

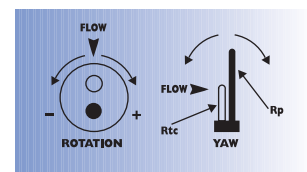
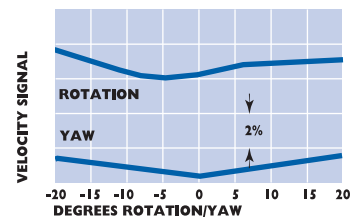

## SPECIFICATIONS

**Process Velocity Range:**  
0-12,000 SFPM

**Process Temperature Rating:**  
HT: -40°C to 260°C  
HHT: -40°C to 500°C

**Pressure Rating:** 150 PSIG  
(10 Barg)

**Sensor Material:**  
Alloy C-276 standard,  
Optional Chromium Nitride  
Coating (450°C max).

**Sensor Support Material:**  
316L Stainless Steel,  
Alloy C-276 Optional.

**Repeatability:** 0.25%

**Velocity Time Constant:**  
1 second for velocity changes  
at 6000 SFPM at a constant  
temperature and 1 second for  
temperature changes at a con-  
stant velocity of 6000 SFPM.

**Process Temperature Time  
Constant:** 8 seconds at a velocity  
of 6000 SFPM.

**Velocity Accuracy:** See Feature  
7 for overall accuracy including  
the effects of process  
temperature.

**Temperature Accuracy:**  
±(1/2% of reading + 1°C) for  
velocities above 100 SFPM.

**Power:** 24 VDC, from a Series  
155 Mass Flow Computer.  
500 mA max. per FD2 sensor.

**Sensor Outputs:**  
Two, linear 4-20 mA for  
velocity and temperature.

**Field Wiring:** Two pairs of twist-  
ed, shielded cable per sensor;  
one pair of 16-18GA shielded  
wire per K-BAR.

**Electrical Enclosure Rating:**  
NEMA 4/IP65 Construction,  
Painted Steel.

**CE Directives:**  
ATEX: Group II, Cat.3,  
Explosive Gas and Dust  
Atmospheres, Ⓢ II3GD,  
EExnAII5 T5X  
PED: Meets PED require-  
ments for ½ to 1½  
Atmosphere  
EMC: 89/336/EEC, Light  
Industrial EN50081-1 and  
heavy Industrial EN 50082-2  
LVD: Directive 73/23/EEC

**Enclosure Temperature:**  
-40°C to 65°C

**Weight Net/Shipping:**  
20 lbs./30 lbs. (Typical)

## TECHNICAL DESCRIPTION

## SENSOR DESIGN

The K-BAR 2000B use the Kurz MetalClad™ FD2 all-welded Alloy C-276 sensor. In this design, the temperature sensor and velocity sensor are mounted in separate tubes (or “stings”), providing exceptional thermal isolation from the sensor support structure and fast response to process temperature changes.

## SENSOR MATERIALS AND CONSTRUCTION

The standard sensor material for all Kurz metal sensors is Alloy C-276. This material is far superior to 316 Stainless Steel in high temperature and corrosive applications. Kurz offers Chromium Nitride coating for abrasive, dirty applications, such as in boiler coal pulverizers. Kurz exclusively uses Inconel sheathed mineral-insulated cable (MI cable) for temperatures above 260°C.

## PROCESS TEMPERATURE RATING

Kurz offers sensor process temperature ratings of 260°C and 500°C. Field data verifies that the lifetime at 500°C is at least five years and the lifetime at 260°C is at least 10 years.

## TRANSMITTER CONFIGURATIONS

Two configurations are available; Directly Attached Electronics Enclosure and Remote Electronic Enclosure.

## PROCESS TEMPERATURE COMPENSATION

The influence of temperature on the thermal properties of gases requires temperature compensation for repeatable and accurate measurements. Standard Temperature Compensation (STC) is used for applications in which the process temperature is below 125°C over a moderate velocity range or below 260°C over a more limited velocity range. If the process temperature and gas velocity vary widely, Velocity/Temperature/Mapping (VTM) is recommended. VTM includes several process temperatures and uses the microprocessor to calculate the velocity based on the built-in process temperature measurement.

## GAS CALIBRATION

Laboratory air calibrations are performed in the Kurz Model 400D NIST traceable wind tunnel.

## RFI, EMI AND PROTECTION

The Sensor Electronics Enclosures include RFI, EMI and Lightning Suppression Circuitry (LSC) and require that the wiring be shielded and placed in well-grounded metal conduit.

## SENSOR PROTECTION

The K-BAR 2000B Electornics includes circuitry to prevent an over-temperature condition caused by a sensor, wiring or component failure. Our sensors will not overheat at zero flow, unlike most competitive devices because of our constant temperature sensor control method and the power limiting design.

AIR PURGE SENSOR  
CLEANING SYSTEM

The K-BAR 2000PB has special nozzles in the sensor windows for use with the Model 148 Sensor Cleaning System. The sensor cleaning is accomplished by a short, high pressure blast of air (sonic velocity) directed at the velocity and temperature sensors. Kurz provides solenoid valves, timer and air blow-down tanks to allow periodic or on-demand cleaning. The measurement value is “held” during the purge cycle. The air blow-down tank uses customer supplied compressed air (instrument quality) at 120 PSIG. The average cleaning air consumption is less than 0.125 SCFM per sensor. The K-BAR 2000PB is designed to measure air flow only at ambient pressure. The primary application is for extremely dirty stacks and ducts having dry particulate matter that may build up on the sensor. Applications include fossil-fueled power boilers, municipal waste incinerators and combustion air flow situations in which fly ash is entrained.

## SENSOR ELECTRONICS

The K-BAR 2000B has several innovations which improve performance, reduce cost and provide extraordinary flexibility. The patented digital sensor control circuit (US Patent 7,418,878) uses an efficient switching power supply. The single-board PCB has an EEPROM loaded with the PCB serial number, calibration coefficients, and component values which insures the safety of the data. The sensor electronics includes a sensor lead resistance compensation circuit which is extremely important for long sensor wires, rapid gas temperature changes and large temperature gradients between the sensor and the ambient air.

## HART

The K-BAR 2000B can be ordered with HART communication interface. This is a useful tool to inquire into the sensor electronics setup by simply connecting to the sensor terminals inside the 155 ADAM Computer. There is no need to access the individual transmitter terminal box.

# K-BAR 2000B MULTI-POINT INSERTION MASS FLOW ELEMENTS

## TECHNICAL DESCRIPTION Cont'd

### EPA FLOW MONITOR DRIFT CHECK

The EPA requires that all Stack Flow Monitors must perform a Zero-Span Flow Rate Drift Check every 24-hours. The K-BAR 2000B includes this function. Some states require a three-point drift check, which is what is incorporated in the new K-BAR 2000B. This is called the Zero-Midspan-Span Drift Check.

Upon receiving a "Start" signal from the user, the K-BAR 2000B electronics will systematically output sequential "Zero-Midspan-Span" Velocity Values (selected by user). These signals will be transmitted to the Series 155 Mass Flow Computer. The user will receive these 4-20 mA outputs separately and compare these to the set-up data. Any meaningful deviations would indicate malfunction in the electronics, or wiring.

### K-BAR DESIGN

The K-BAR 2000B is a self-supporting structure. It has up to three K-BAR Segments plus the Flange-To-Inside Wall Segment (SFTIW) having different diameters and lengths to allow installations in larger ducts and stacks. The segments may be constructed of all Stainless Steel or a combination of 316L Stainless Steel for the #1, 2, 3 Segments and Alloy C-276 for the SFTIW and Flange. This construction is routinely used in fossil fuel power plants having a corrosion problem caused by sulfuric acid.

The number of sensors selected for each K-BAR Mass Flow Element and the number of K-BAR's is determined by the stack/duct dimensions, velocity profiles and accuracy requirements. The maximum number of sensors on a K-BAR is four (4). Stainless Steel Identification tags are standard and are attached to the K-BAR mounting flange.

There are three K-BAR 2000B Construction Types. Please see K-BAR Nomenclature for description of the identifiers used below:

■ **TYPE 1:** One K-BAR Segment (S1) welded to the Flange-To-Inside Wall Segment (SFTIW), which in turn is welded to the Mounting Flange (MTGFL). Segment #1 is available in Type 316L Stainless Steel. SFTIW and MTGFL can be Type 316L Stainless Steel or Alloy C-276 for superior corrosion resistance. These are used in smaller stacks and ducts up to about 20 feet.

■ **TYPE 2:** Two K-BAR Segments (S1 & S2) in which S1 is welded to S2 which is welded to SFTIW which is welded to MTGFL. Type 2 K-BARs are used for stacks and ducts up to 30 feet and CEM Stack Flow Monitors which may have sulfuric acid mist. Thus, the Mounting Flange and SFTIW are constructed from Alloy C-276 and Segment #1 and #2 are constructed of 316L Stainless Steel.

■ **TYPE 3:** Three K-BAR Segments (S1, S2, S3) in which S1 is welded to S2 which is welded to S3 which is welded to SFTIW which is welded to the MTGFL. Type 3 K-BAR's are usually used for stacks and ducts up to about 35 feet. For CEM Monitors, SFTIW and MTGFL are constructed of Alloy C-276, and S1, S2, S3 are constructed of 316LSS.

There are eight (8) K-BAR 2000B Installation Configuration Categories:  
**CATEGORY A:** Round Stack/Duct, Half Span, Single-End Support.  
**CATEGORY B:** Round Stack/Duct, Full Span, Single-End Support.  
**CATEGORY C:** Round Stack/Duct, Full Span, External-End Support.  
**CATEGORY D:** Round Stack/Duct, Full Span, Internal-End Support.  
**CATEGORY E:** Rectangular Stack/Duct, Half Span, Single-End-Support.  
**CATEGORY F:** Rectangular Stack/Duct, Full Span, Single-End Support.  
**CATEGORY G:** Rectangular Stack/Duct, Full Span, External-End Support.  
**CATEGORY H:** Rectangular Stack/Duct, Full Span, Internal-End Support.

There are two K-BAR Sensor Electronics Enclosure Configurations:

- **Directly Attached Electronics Enclosure.** The Model 196TA-4B Electronics Enclosure is mounted directly on the flange end of the K-BAR 2000B and houses the individual MFTB sensor electronics circuit boards.
- **Remote Electronics Enclosure.** The Model 196TS-4B Remote Electronics Enclosure is connected via grounded conduit to the Model 190-4B Sensor Wire Junction Box mounted on the end of the K-BAR 2000B. The Sensor Electronics Enclosure Configurations include RFI, EMI and Lightning Suppression Circuitry (LSC) and require that the wiring be shielded and placed in well-grounded conduit.

### NOMENCLATURE:

SENSOR TYPE	
Identifier	Description
FD2	Fast Dual MetalClad™ Velocity and Temperature Sensor, all-welded construction, 0.105" diameter sensor stings

PROCESS TEMPERATURE RATING		
Identifier	Description	Range
HT	High Temperature	-40°F to 500°F -40°C to 260°C
HHT	Very High Temperature	-40°F to 932°F -40°C to 500°C

K-BAR NOMENCLATURE (Note 1)	
Identifier	Description
D	The Round Stack/Duct Diameter or Rectangular Stack/Duct Flow Dimension (inches).
D <sub>MAX</sub>	The maximum allowable Flow Dimension (inches) for the selected Category and Type.
D <sub>MIN</sub>	The minimum allowable Flow Dimension (inches) for the selected Category and Type.
FTIW	The length of that portion of the K-BAR between the Mounting Flange surface and the Inside Stack/Duct Wall, including gaskets, flanges and stack/duct wall thickness(inches).
L <sub>1</sub>	Length of Segment #1 for a Type 1, 2, and 3 K-BAR (inches).
L <sub>2</sub>	Length of Segment #2 for a Type 2 and 3 K-BAR (inches).
L <sub>3</sub>	Length of Segment #3 for a Type 3 K-BAR (inches).
L	The total length of the K-BAR (inches); L = L <sub>1</sub> + L <sub>2</sub> + L <sub>3</sub> + FTIW
S <sub>1</sub>	K-BAR Segment #1.
S <sub>2</sub>	K-BAR Segment #2.
S <sub>3</sub>	K-BAR Segment #3.
SFTIW	K-BAR FTIW Segment
MTGFL	K-BAR Mounting Flange

# K-BAR 2000B MULTI-POINT INSERTION MASS FLOW ELEMENTS

K-BAR NOMENCLATURE (Note 1) continued	
Identifier	Description
U <sub>1</sub>	Location of 1st sensor from Inside Stack/Duct Wall (inches).
U <sub>2</sub>	Location of 2nd sensor from Inside Stack/Duct Wall (inches).
U <sub>3</sub>	Location of 3rd sensor from Inside Stack/Duct Wall (inches).
U <sub>4</sub>	Location of 4th sensor from Inside Stack/Duct Wall (inches).
W <sub>1</sub>	Duct Wall thickness (inches) at FTIW location.
W <sub>2</sub>	Duct Wall thickness at external end support cap location

## K-BAR DESIGN DATA

The following Tables give detailed design data for each of the Configuration Categories and Construction Types based upon the Stack/Duct Flow Dimension (D), the Flange-To-Inside-Wall (FTIW) length, the length of the K-BAR Segments and selected dimensions to insure proper mounting of the K-BAR. The Design Data contained in the following Tables 1-12 is based upon the following considerations:

- For Single-End Supported, Half-Span and Full-Span K-BAR's (CATEGORIES A, B, E & F) the standard distance between the centerline of the outermost velocity sensor and the K-BAR tip is 2.5".
- For External-End Supported Full-Span K-BAR's (CATEGORIES C & G) Segment #1 has been designed to Span 3.0" past the duct wall into an External End Support Cup PN 759017 (See Section B-3) having a length of 4.0".
- For Internal-End Supported Full-Span K-BAR's (CATEGORIES D & H) Segment #1 has been designed to be 2.0" from the outer Stack/Duct wall and supported by Internal End Support Cup, PN 759018 (See Section B-10) having a length of 3".
- For all K-BAR's, the Segment lengths, diameters and allowable Flange-To-Inside-Wall Dimensions are based upon experimental data and structural calculations to insure that the K-BAR natural frequency is greater than 7 Hertz, a value shown to be valid over our many years of experience and seismic testing.

**Table 1** lists CATEGORY A Design Data (Round Stack/Duct, Half Span, Single-End Support), Types 1, 2, 3.

**Table 2** lists CATEGORY B Design Data (Round Stack/Duct, Full Span, Single-End Support), Types 1 and 2.

**Table 3** lists CATEGORY C Design Data (Round Stack/Duct, Full Span, External End Support), Type 1.

**Table 4** lists CATEGORY D Design Data (Round Stack/Duct, Full Span, Internal End Support), Type 1.

**Table 5** lists CATEGORY E Design Data (Rectangular Stack/Duct, Half Span, Single-End Support), Types 1, 2, 3.

**Table 6** lists CATEGORY F Design Data (Rectangular Stack/Duct, Full Span, Single-End Support), Types 1 and 2.

**Table 7** lists CATEGORY G Design Data (Rectangular Stack/Duct, Full Span, External End Support), Type 1.

**Table 8** lists CATEGORY H Design Data (Rectangular Stack/Duct, Full Span, Internal End Support), Type 1.

**Table 9** lists the U Dimensions for CATEGORY A (Round Stack/Duct, Half-Span, Single-End Support).

**Table 10** lists the U dimensions for CATEGORIES B, C, D (Round Stack/Duct, Full-Span, Single-End, External and Internal End Supports respectively).

**Table 11** lists the U Dimensions for a CATEGORY E (Rectangular Stack/Duct, Half-Span, Single-End Support).

**Table 12** lists the U Dimension for CATEGORIES F, G, H (Rectangular Stack/Duct, Full-Span, Single-End, External and Internal End Supports, respectively).

TABLE 1: CATEGORY A DESIGN DATA (ROUND STACK/DUCT, HALF SPAN, SINGLE-END SUPPORT)			
CATEGORY A, TYPE 1			
Description	Number of Sensors		
	2	3	4
D <sub>MAX</sub>	306 - 4.0 FTIW	259 - 3.38 FTIW	237 - 3.094 FTIW
D <sub>MIN</sub>	37	57	77
L <sub>1</sub>	.25D + 2.5	.2959D + 2.5	.3232D + 2.5
L	.25D + 2.5 + FTIW	.2959D + 2.5 + FTIW	.3232D + 2.5 + FTIW
MTGFL	1 1/2 Min.	1 1/2 Min.	1 1/2 Min.
Sensors S <sub>1</sub>	2	3	4
CATEGORY A, TYPE 2			
Description	Number of Sensors		
	2	3	4
D <sub>MAX</sub>	492 - 3.492 (FTIW) <sup>1.114</sup>	418 - 1.358 (FTIW) <sup>1.153</sup>	387 - 1.562 (FTIW) <sup>1.108</sup>
D <sub>MIN</sub>	45	69	93
L <sub>1</sub>	.125D	.1495D - 3	.1294 + 5.5
L <sub>2</sub>	.125D + 2.5	.1464D + 5.5	.1938D - 3
L	.25D + 2.5 + FTIW	0.2959D + 2.5 + FTIW	.3232D + 2.5 + FTIW
MTGFL	3 1/2 Min.	3 1/2 Min.	3 1/2 Min.
Sensors S <sub>1</sub>	1	1	2
Sensors S <sub>2</sub>	1	2	2
CATEGORY A, TYPE 3			
Description	Number of Sensors		
	3	4	
D <sub>MAX</sub>	461 - .712 (FTIW) <sup>1.235</sup>	407 - .489 (FTIW) <sup>1.276</sup>	
D <sub>MIN</sub>	172	232	
L <sub>1</sub>	0.120D + 2.5	0.12940 + 5	
L <sub>2</sub>	0.1323D - 3	0.1615D + 0.5	
L <sub>3</sub>	0.0436D - 3	0.0323D - 3	
L	0.2959D + 2.5 + FTIW	0.3232D + 2.5 + FTIW	
MTGFL	6 Min.	6 Min.	
Sensors S <sub>1</sub>	1	2	
Sensors S <sub>2</sub>	2	2	
Sensors S <sub>3</sub>	0	0	

Dimensions in inches.

TABLE 2: CATEGORY B DESIGN DATA (ROUND STACK/DUCT, FULL SPAN, SINGLE-END SUPPORT)			
CATEGORY B, TYPE 1			
Description	Number of Sensors		
	2	3	4
D <sub>MAX</sub>	90 - 1.172 FTIW	84 - 1.10 FTIW	82 - 1.072 FTIW
D <sub>MIN</sub>	21	33	45
L <sub>1</sub>	.8536D + 2.5	.9082D + 2.5	.9330D + 2.5
L	.8536D + 2.5 + FTIW	.9082D + 2.5 + FTIW	.9330D + 2.5 + FTIW
MTGFL	1 1/2 Min.	1 1/2 Min.	1 1/2 Min.
Sensors S <sub>1</sub>	2	3	4

Dimensions in inches.

# K-BAR 2000B MULTI-POINT INSERTION MASS FLOW ELEMENTS

TABLE 2: CATEGORY B DESIGN DATA (ROUND STACK/DUCT, FULL SPAN, SINGLE-END SUPPORT) Continued			
CATEGORY B, TYPE 2			
Description	Number of Sensors		
	2	3	4
D <sub>MAX</sub>	146 - .451 (FTIW) <sup>1.193</sup>	136 - .422 (FTIW) <sup>1.168</sup>	131 - .620 (FTIW) <sup>1.150</sup>
D <sub>MIN</sub>	21	33	45
L <sub>1</sub>	.380D	.4082D + 5.0	.415D
L <sub>2</sub>	.4736D + 2.5	.50D - 2.5	.518D + 2.5
L	.8536D + 2.5 + FTIW	.9082D + 2.5 + FTIW	.9330D + 2.5 + FTIW
MTGFL	3 1/2 Min.	3 1/2 Min.	3 1/2 Min.
Sensors S <sub>1</sub>	1	2	2
Sensors S <sub>2</sub>	1	1	2

Dimensions in inches.

TABLE 3: CATEGORY C DESIGN DATA (ROUND STACK/DUCT, FULL SPAN, EXTERNAL END SUPPORT)			
CATEGORY C, TYPE 1			
Description	Number of Sensors		
	2	3	4
D <sub>MAX</sub>	173 - FTIW	173 - FTIW	173 - FTIW
D <sub>MIN</sub>	17	27	38
L <sub>1</sub>	D + 3	D + 3	D + 3
L	D + 3 + FTIW + W <sub>2</sub>	D + 3 + FTIW + W <sub>2</sub>	D + 3 + FTIW + W <sub>2</sub>
MTGFL	1 1/2 Min.	1 1/2 Min.	1 1/2 Min.
Sensors S <sub>1</sub>	2	3	4

Dimensions in inches.

TABLE 4: CATEGORY D DESIGN DATA (ROUND STACK/DUCT, FULL SPAN, INTERNAL END SUPPORT)			
CATEGORY D, TYPE 1			
Description	Number of Sensors		
	2	3	4
D <sub>MAX</sub>	173 - FTIW	173 - FTIW	173 - FTIW
D <sub>MIN</sub>	17	27	38
L <sub>1</sub>	D - 2.0	D - 2.0	D - 2.0
L	D - 2.0 + FTIW	D - 2.0 + FTIW	D - 2.0 + FTIW
MTGFL	1 1/2 Min.	1 1/2 Min.	1 1/2 Min.
Sensors S <sub>1</sub>	2	3	4

Dimensions in inches.

TABLE 5: CATEGORY E DESIGN DATA (RECT. STACK/DUCT, HALF SPAN, SINGLE-END SUPPORT)			
CATEGORY E, TYPE 1			
Description	Number of Sensors		
	2	3	4
D <sub>MAX</sub>	204 - 2.67 FTIW	183 - 2.4 FTIW	175 - 2.286 FTIW
D <sub>MIN</sub>	28	42	56
L <sub>1</sub>	.375D + 2.5	.4167D + 2.5	.4375D + 2.5
L	.375D + 2.5 + FTIW	.4167D + 2.5 + FTIW	.4375D + 2.5 + FTIW
MTGFL	1 1/2 Min.	1 1/2 Min.	1 1/2 Min.
Sensors S <sub>1</sub>	2	3	4

TABLE 5: CATEGORY E DESIGN DATA (RECT. STACK/DUCT, HALF SPAN, SINGLE-END SUPPORT) Continued			
CATEGORY E, TYPE 2			
Description	Number of Sensors		
	2	3	4
D <sub>MAX</sub>	333 - 1.11 (FTIW) <sup>1.169</sup>	300 - 1.085 (FTIW) <sup>1.145</sup>	285 - .922 (FTIW) <sup>1.175</sup>
D <sub>MIN</sub>	36	54	72
L <sub>1</sub>	.167D	.1667D + 5	.1975 D
L <sub>2</sub>	.2080D + 2.5	.25D - 2.5	.240D + 2.5
L	.375D + 2.5 + FTIW	.4167D + 2.5 + FTIW	.4375D + 2.5 + FTIW
MTGFL	3 1/2 Min.	3 1/2 Min.	3 1/2 Min.
Sensors S <sub>1</sub>	1	2	2
Sensors S <sub>2</sub>	1	1	2

CATEGORY E, TYPE 3		
Description	Number of Sensors	
	3	4
D <sub>MAX</sub>	335 - .406 (FTIW) <sup>1.319</sup>	312 - .359 (FTIW) <sup>1.323</sup>
D <sub>MIN</sub>	90	120
L <sub>1</sub>	0.1667D + 5.5	.167D + 2.5
L <sub>2</sub>	0.1667D	.208D + 3
L <sub>3</sub>	.0833D - 3	.0625D - 3
L	0.4167D + 2.5 + FTIW	.4375D + 2.5 + FTIW
MTGFL	6 Min.	6 Min.
Sensors S <sub>1</sub>	2	2
Sensors S <sub>2</sub>	1	2
Sensors S <sub>3</sub>	0	0

Dimensions in inches.

TABLE 6: CATEGORY F DESIGN DATA (RECT. STACK/DUCT, FULL SPAN, SINGLE-END SUPPORT)			
CATEGORY F, TYPE 1			
Description	Number of Sensors		
	2	3	4
D <sub>MAX</sub>	102 - 1.333 FTIW	92 - 1.20 FTIW	87 - 1.143 FTIW
D <sub>MIN</sub>	14	21	28
L <sub>1</sub>	.75D + 2.5	.8333D + 2.5	.875D + 2.5
L	.75D + 2.5 + FTIW	.8333D + 2.5 + FTIW	.875D + 2.5 + FTIW
MTGFL	1 1/2 Min.	1 1/2 Min.	1 1/2 Min.
Sensors S <sub>1</sub>	2	3	4

CATEGORY F, TYPE 2			
Description	Number of Sensors		
	2	3	4
D <sub>MAX</sub>	167 - .655 (FTIW) <sup>1.116</sup>	150 - .58 (FTIW) <sup>1.122</sup>	143 - .52 (FTIW) <sup>1.139</sup>
D <sub>MIN</sub>	18	27	36
L <sub>1</sub>	.330D	.3333D + 5	.390D
L <sub>2</sub>	.42D + 2.5	.50D - 2.5	.485D + 2.5
L	.75D + 2.5 + FTIW	.8333D + 2.5 + FTIW	.875D + 2.5 + FTIW
MTGFL	3 1/2 Min.	3 1/2 Min.	3 1/2 Min.
Sensors S <sub>1</sub>	1	2	2
Sensors S <sub>2</sub>	1	1	2

Dimensions in inches.

# K-BAR 2000B MULTI-POINT INSERTION MASS FLOW ELEMENTS

TABLE 7: CATEGORY G DESIGN DATA (RECT. STACK/DUCT, FULL SPAN, EXTERNAL-END SUPPORT)			
CATEGORY G, TYPE 1			
Description	Number of Sensors		
	2	3	4
D <sub>MAX</sub>	173 - FTIW	173 - FTIW	173 - FTIW
D <sub>MIN</sub>	14	21	28
L <sub>1</sub>	D + 3.0	D + 3.0	D + 3.0
L	D + 3.0 + FTIW + W <sub>2</sub>	D + 3.0 + FTIW + W <sub>2</sub>	D + 3.0 + FTIW + W <sub>2</sub>
MTGFL	1 1/2 Min.	1 1/2 Min.	1 1/2 Min.
Sensors S <sub>1</sub>	2	3	4

Dimensions in inches.

TABLE 8: CATEGORY H DESIGN DATA (RECT. STACK/DUCT, FULL SPAN, INTERNAL-END SUPPORT)			
CATEGORY H, TYPE 1			
Description	Number of Sensors		
	2	3	4
D <sub>MAX</sub>	173 - FTIW	173 - FTIW	173 - FTIW
D <sub>MIN</sub>	14	21	28
L <sub>1</sub>	D - 2.0	D - 2.0	D - 2.0
L	D - 2.0 + FTIW	D - 2.0 + FTIW	D - 2.0 + FTIW
MTGFL	1 1/2 Min.	1 1/2 Min.	1 1/2 Min.
Sensors S <sub>1</sub>	2	3	4

TABLE 9: U DIMENSIONS FOR CATEGORY A				
Number of Sensors	U <sub>1</sub>	U <sub>2</sub>	U <sub>3</sub>	U <sub>4</sub>
2	.0670D	.25D		
3	.0436D	.1464D	.2959D	
4	.0323D	.1047D	.1938D	.3232D

TABLE 10: U DIMENSIONS FOR CATEGORY B, C, D				
Number of Sensors	U <sub>1</sub>	U <sub>2</sub>	U <sub>3</sub>	U <sub>4</sub>
2	.1464D	.8536D		
3	.0918D	.5000D	.9082D	
4	.0670D	.2500D	.7500D	.9330D

TABLE 11: U DIMENSIONS FOR CATEGORY E				
Number of Sensors	U <sub>1</sub>	U <sub>2</sub>	U <sub>3</sub>	U <sub>4</sub>
2	.1250D	.3750D		
3	.0833D	.2500D	.4167D	
4	.0625D	.1875D	.3125D	.4375D

TABLE 12: U DIMENSIONS FOR CATEGORY F, G, H				
Number of Sensors	U <sub>1</sub>	U <sub>2</sub>	U <sub>3</sub>	U <sub>4</sub>
2	.250D	.75D		
3	.1667D	.500D	.8333D	
4	.1250D	.375D	.625D	.875D

RANGE OF MODELS AND KEY FEATURES			
Model Number	Parent Number	Process Temperature Rating	Sensor Clean Air Purge
K-BAR 2000B-HT	753731	HT	No
K-BAR 2000B-HHT	753732	HHT	No
K-BAR 2000BP-HHT	753733	HHT	Yes

## PART NUMBER GENERATION PROCEDURE

Using the chosen Parent Number specify the entire Part Number by selecting an Option for each Feature as shown in the example Part Number below. Refer to the K-BAR Design Data listed in Tables 1-8 to determine the Category, Type, Stack/Duct Dimension and the Flange-To-Inside-Wall (FTIW) Length. See the example at the end of this document.

753731 A 3360 A 3 C 240 C 43 U 3 M 2223

Parent Number F1 F2 F3 F4 F5 F6 F7 F8 F9 F10 F11 F12

SUMMARY OF FEATURES	
Feature	Feature Description
1	K-BAR Installation Configuration Category
2	Stack/Duct Flow Dimension (D)
3	Sensor Electronics Enclosure Configuration
4	K-BAR Construction Type
5	Sensor Electronics and Outputs
6	Flange-To-Inside-Wall-Length (FTIW)
7	Process Temperature Compensation
8	Number of FD2 Sensors/Sensor Material
9	Mounting Flange Size
10	Mounting Flange Material
11	Laboratory Air Velocity Calibration
12	K-BAR Segments S1/S2/S3/SFTIW Materials

FEATURE 1: K-BAR INSTALLATION CONFIGURATION CATEGORY	
Option	Feature Description
A	Category A, Round Stack/Duct, Half Span, Single-End Support, Types 1, 2, 3
B	Category B, Round Stack/Duct, Full Span, Single-End Support, Types 1, 2
C	Category C, Round Stack/Duct, Full Span, External End Support, Type 1
D	Category D, Round Stack/Duct, Full Span, Internal End Support, Type 1
E	Category E, Rectangular Stack/Duct, Half Span, Single-End Support, Types 1, 2, 3
F	Category F, Rectangular Stack/Duct, Full Span, Single-End Support, Types 1, 2
G	Category G, Rectangular Stack/Duct, Full Span, External End Support, Type 1
H	Category H, Rectangular Stack/Duct, Full Span, Internal End Support, Type 1

# K-BAR 2000B MULTI-POINT INSERTION MASS FLOW ELEMENTS

FEATURE 2: STACK/DUCT FLOW DIMENSIONS (D)	
Directions: Enter the Stack/Duct Flow Dimension in units of inches. If the Stack/Duct is round, enter the inside diameter to the nearest tenth inch. If the Stack/Duct is Rectangular, enter the inside dimension measured along the axis of the K-BAR to be inserted to the nearest tenth inch. Enter four digits. No Charge.	
Example: A round Stack has an inside diameter of 336 inches. Enter 3360.	

FEATURE 3: SENSOR ELECTRONICS ENCLOSURE CONFIGURATION	
Option	Description
A	Directly Attached Electronics Enclosure for up to four sensors. Model 196-4B. NEMA 4 Powder-Coated Polyester Steel Enclosure with 1" FNPT conduit hubs. Meets CE Compliance. Includes one Stainless Steel I.D. Tag.
B	Remote Electronics Enclosure. Model 196-4B Electronics Enclosure and Model 190-4B Sensor Wire Junction Box for up to four sensors. NEMA 4 Powder-Coated Polyester Steel Enclosures with 1" FNPT conduit hubs. Includes two Stainless Steel I.D. Tags.

FEATURE 4: K-BAR CONSTRUCTION TYPE	
Option	Feature Description
1	One Segment K-BAR and SFTIW Segment. All CATEGORIES
2	Two Segment K-BAR and SFTIW Segment. A, B, E, F
3	Three Segment K-BAR and SFTIW Segment. CATEGORIES A & E

FEATURE 5: ANALOG AND DIGITAL INPUTS/COMMUNICATIONS						
Option	Analog & Digital Inputs				Communication Protocols	
	No. of Alarm Relay Outputs	No. of 4-20mA Outputs (DO)	No. of Digital Inputs (AO)	No. of 4-20mA Inputs (DI)	USB (DI)	Modbus RS-485 RTU or ASC II
C <sup>1</sup>	2	2	2	1	Yes	Yes
E <sup>2</sup>	2	1	2	1	Yes	Yes

<sup>1</sup>Required for Process Measurement Velocity and Temperature Outputs, NAMUR NE-43 Alarms, Daily "Zero-MidSpan-Span" EPA Drift Check and Acknowledgement, Alarm Relays. Model 148 Automatic Sensor Cleaning for the K-BAR 2000BP.

<sup>2</sup>Same as Note 1 but only one 4-20 mA output. Hart Communication Interface.

FEATURE 6: FLANGE-TO-INSIDE-WALL LENGTH (FTIW)	
Instructions: Enter the length from the Mating Surface of the K-BAR Mounting Flange to the inside wall of the Stack/Duct. This should include the distance between the Mating Surface of the Stack Mounting Flange to the inside wall of the Stack/Duct including the Gasket Thickness and the Stack/Duct wall thickness. Enter the FTIW length to the nearest tenth inch. Enter three digits. No Charge.	
Example: The distance between the Stack Mounting Flange, including the gasket and wall thickness to the Stack/Duct Inside Wall is 56.25 inches, enter 563.	

FEATURE 7: PROCESS TEMPERATURE COMPENSATION	
The influence of temperature on the thermal properties of gases requires temperature compensation for repeatable and accurate measurements. Standard Temperature Compensation (STC) is used for applications in which the process temperature is below 125°C over a moderate velocity range (Option A), or below 260°C over more limited velocity range (Option B). Standard Temperature Compensation is accomplished by taking experimental data on the mass flow sensor at two process temperatures at the same velocity in high temperature air wind tunnel at atmospheric pressure.	
If the process temperature and gas velocity vary widely, Velocity/Temperature/Mapping (VTM) is recommended. VTM (Options C, D) includes the standard temperature compensation procedure but also includes using two or three velocity data sets in air at higher temperatures. These multiple velocity data sets are entered into the MFTB Microprocessor which performs a double interpolation between the velocity calibration curves using the built-in process gas temperature measurement. Since each sensor measures its own ambient temperature, VTM works extremely well for highly non-uniform temperature and velocity profiles.	
Option	Description
A	Standard Temperature Compensation (STC) over process Temperature range of -40°C to +125°C. Accuracy: ± ( 1% Reading + 20 SFPM) above or below 25°C, (see note 1).
B	Standard Temperature Compensation (STC) over process Temperature range of 0°C to 260°C. Accuracy: ± ( 2% Reading + 20 SFPM) above or below 125°C (see note 1).
C	Velocity/Temperature/Mapping (VTM) with data over process temperature range of 0°C up to 260°C. Accuracy: ±(2% Reading + 20 SFPM)
D	Velocity/Temperature/Mapping (VTM) with data over process temperature range of 0°C up to 500°C. Accuracy: ±(3% Reading + 30 SFPM)

**Note 1:** An accuracy specification of ± ( 0.025%/°C Reading + 0.25 SFPM/°C) should added for temperatures above or below standard.

FIRST DIGIT OF FEATURE 8: NUMBER OF FD2 SENSORS	
Option	Number
2	Two
3	Three
4	Four

SECOND DIGIT OF FEATURE 8: SENSOR MATERIAL	
Option	Description
3	Alloy C-276
7	Alloy C-276 with Chromium Nitride Sensor Coating

FEATURE 9: MOUNTING FLANGE SIZE			
Option	Flange Size	Option	Flange Size
H	1½"	Q	3½"
J	2"	S	4"
L	2½"	U	6"
N	3"		

**Note 1:** Raised Face Class 150 ANSI B16.5.

# K-BAR 2000B MULTI-POINT INSERTION MASS FLOW ELEMENTS

FEATURE 10: MOUNTING FLANGE MATERIAL	
Option	Description
2	316L Stainless Steel
3	Alloy C-276

FEATURE 11: LABORATORY AIR VELOCITY CALIBRATION			
Standard conditions (STP) are 77°F and 14.69 PSIA for English units, and 0°C and 760 mm HG for Metric units. If different standard conditions are required, specify the required conditions on the purchase order. A sufficient number of calibration data points are taken to ensure accuracy over the entire range. The temperature calibration data range corresponds to the selected process temperature range (HT or HHT). SFPM means Standard-Foot-Per-Minute; NMPS means Normal-Meters-Per-Second.			
Option	SFPM (NMPS)	Option	SFPM (NMPS)
A	300 (1.4)	K	4,000 (18.6)
C	600 (2.8)	M	6,000 (28)
E	1,000 (4.7)	P	9,000 (41.9)
G	2,000 (9.3)	R	12,000 (56)
I	3,000 (14)		

FIRST DIGIT OF FEATURE 12: SEGMENT #1 MATERIAL				
Material Option	Model	K-BAR Category	K-BAR Type	Segment Size
2 316LSS	2000B	All	1, 2, 3	1.5" Tube x .065" Wall
	2000PB			
3 Alloy C-276	2000B	All	1	1.5" Tube x .065" Wall
	2000PB			

SECOND DIGIT OF FEATURE 12: SEGMENT #2 MATERIAL (Note 1)				
Material Option	Model	K-BAR Category	K-BAR Type	Segment Size
2 316LSS	2000B	All	2, 3	2½" Sch. 10 Pipe
	2000PB			

Note 1: If L<sub>2</sub> = 0, Enter 0 as the Default Material Option.

THIRD DIGIT OF FEATURE 12: SEGMENT #3 MATERIAL (Note 1)				
Material Option	Model	K-BAR Category	K-BAR Type	Segment Size
2 316LSS	2000B	A & E	3	4" Sch. 10 Pipe
	2000PB			

Note 1: If L<sub>3</sub> = 0 use 0 as the Material Option. Segment #3 does not have sensors.

FOURTH DIGIT OF FEATURE 12: SEGMENT FTIW MATERIAL				
Material Option	Model	K-BAR Category	K-BAR Type	Segment Size
2 316LSS	2000B	All	1	1.5" Tube x .065" Wall
	2000PB	A, B, E, F	2	2½" Sch 10 Pipe
		A, E	3	4" Sch. 10 Pipe
3 Alloy (C-276)	2000B	All	1	1.5" Tube x .065" Wall
	2000PB	A, B, E, F	2	2½" Sch 10 Pipe
		A, E	3	4" Sch. 10 Pipe

## ORDERING INFORMATION

Using the K-BAR Quotation Request and Part Number/Order Sheet:

- A** Complete the Application Information Section.
- B** Enter the complete K-BAR Part Number(s).
- C** Enter the K-BAR mounting hardware and accessory Part Numbers.
- D** Contact the Kurz Representative or the Kurz Factory to place the order or to obtain additional information.

## PART NUMBER GENERATION EXAMPLE

This application is for measuring the primary air mass flow into a coal pulverizer. The maximum process air temperature is 700°F and large changes in temperature can occur because the K-BAR is downstream of the junction of hot and cold air ducts, so VTM is selected. The duct is 2' x 4' and it has been determined that two, Type 1 K-BARS, each with two FD2-HHT sensors located at equal area locations and extending into the 4' dimension is selected. Category G installation with an external end support. FTIW is 4". The Series 155 Mass Flow Computer will be mounted 100 feet away in a well ventilated area. The average velocity is 4,000 SFPM, so 6000 SFPM will be selected as a calibration data range. The Series 155C-2 will be used and set up to have one 4-20 mA output for the flow rate, and one 4-20 mA for the average air temperature (See the 155 Brochure). The Part Number is:

753732 G 480 B 1 B 040 D 23 H 2 M 2002

Parent Number F1 F2 F3 F4 F5 F6 F7 F8 F9 F10 F11 F12

**TYPICAL K-BAR INSTALLATION CONFIGURATIONS**

**ROUND STACKS/DUCTS**

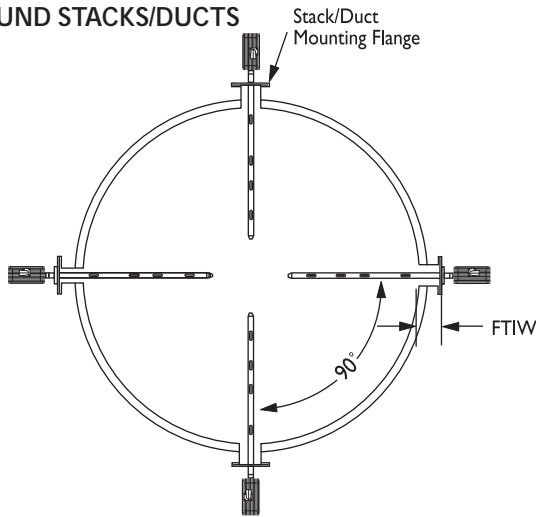

*Category A: Half Span, Single-End Support*

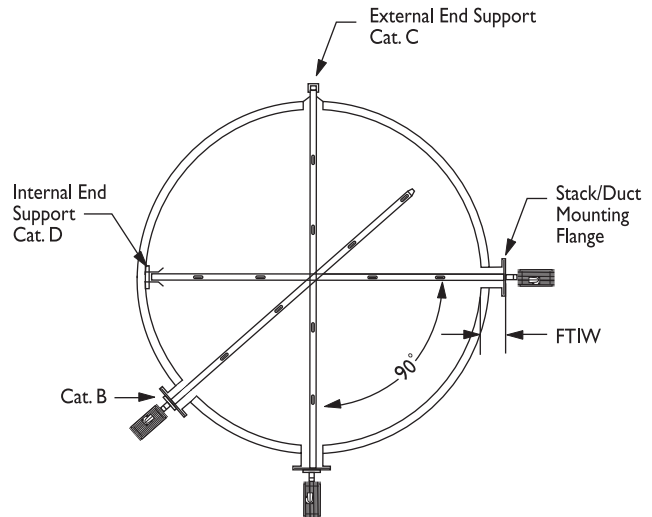

*Category B : Full Span, Single-End Support  
Category C : Full Span, External-End Support  
Category D : Full Span, Internal-End Support*

**RECTANGULAR STACKS/DUCTS**

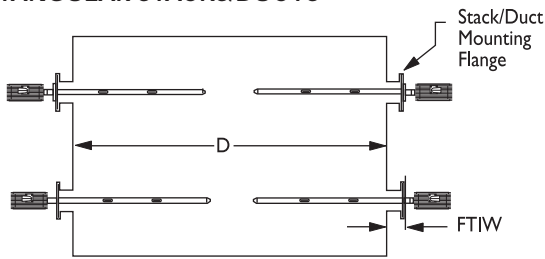

*Category E: Half Span, Single-End Support*

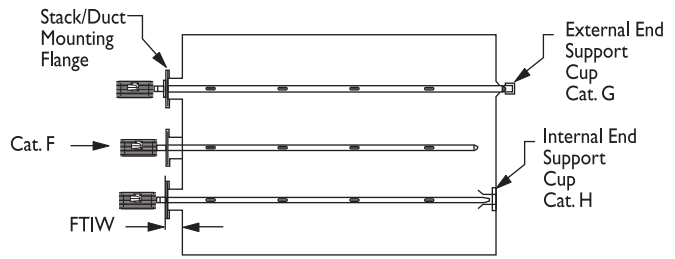

*Category F: Full Span, Single-End Support  
Category G: Full Span, External-End Support  
Category H: Full Span, Internal-End Support*

**SENSOR ELECTRONICS CONFIGURATIONS**

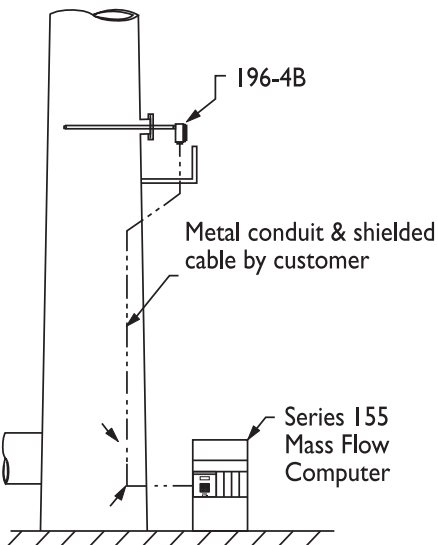

*Feature 3, Option A Directly Attached*

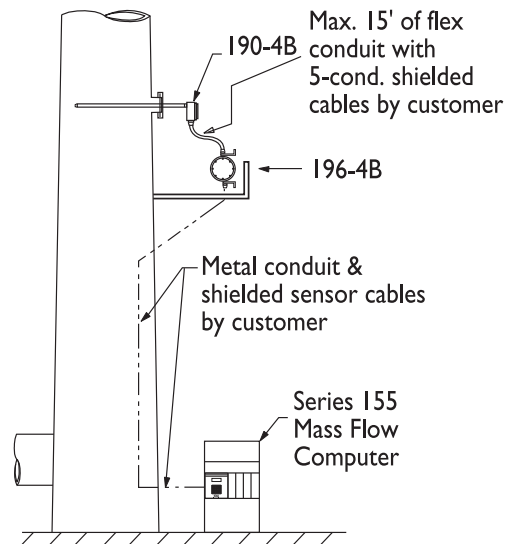

*Feature 3, Option B Remote*

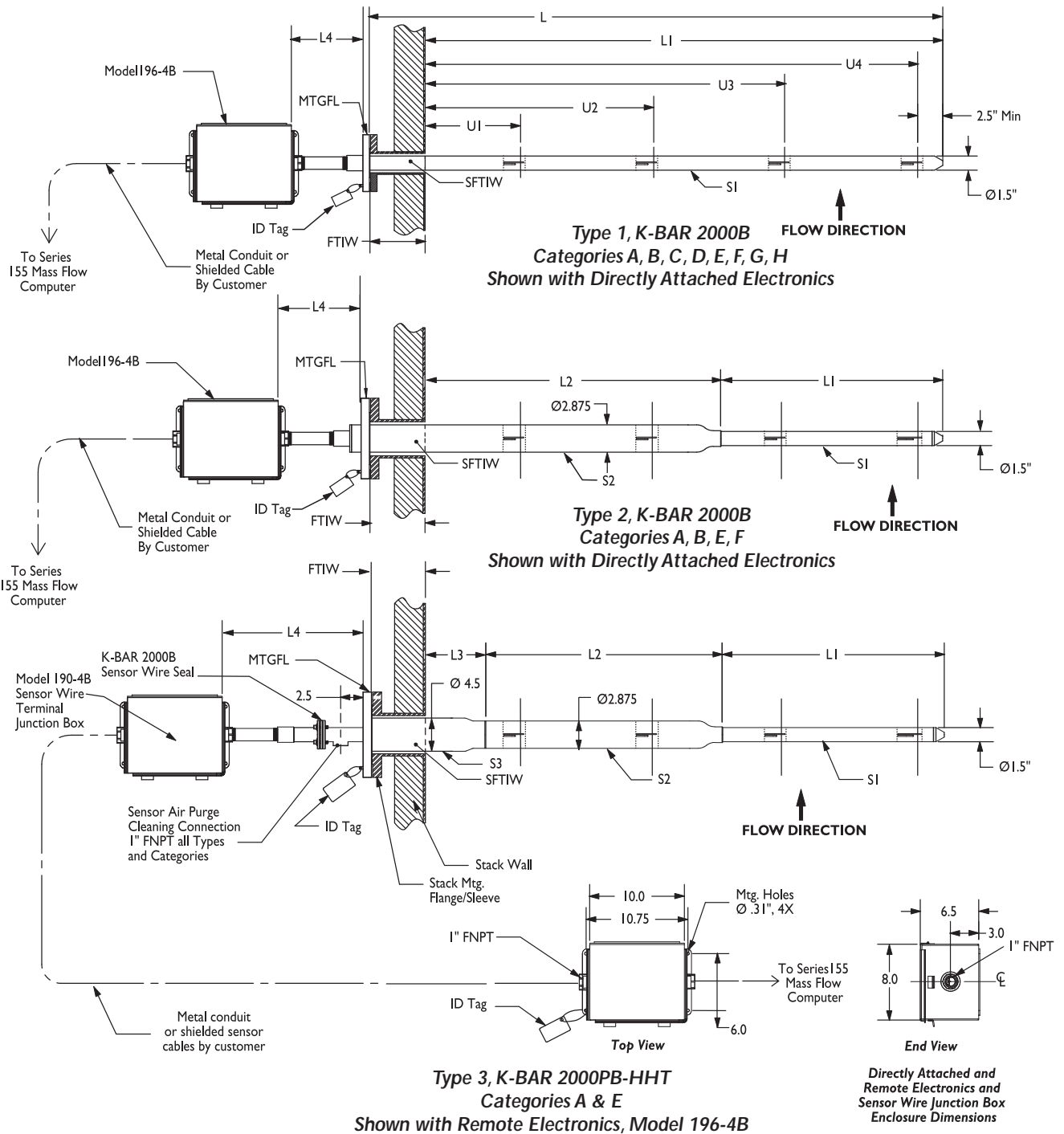

L4 DIMENSIONS IN INCHES	
K-BAR 2000B-MT	8"
K-BAR 2000B-HHT	12"
K-BAR 2000PB-HHT	12"

Note: Dimensions in inches

The leader in Mass Flow  
Technology for Process and  
Environmental Measurements



Kurz Instruments, Inc.

2411 Garden Road, Monterey, CA 93940

800-424-7356 ■ 831-646-5911 ■ Fax 831-646-8901

[www.kurzinstruments.com](http://www.kurzinstruments.com)

e-mail: [sales@kurzinstruments.com](mailto:sales@kurzinstruments.com)