

In-Line Flow Meter Series 504FTB

The Kurz 504FTB in-line thermal mass flow meter for applications ranging from vacuum service up to 300 PSIG includes the qualities and features found in all Kurz constant temperature thermal flow meters that make them outperform all other currently available thermal mass flow meters, including:

- The highest repeatability, accuracy, and reliability available
- The fastest response to temperature and velocity changes in the industry
- Constant temperature thermal technology
- High turndown ratio
- Low flow noise
- Continuous self-monitoring electronics that verify the integrity of sensor wiring and measurements
- Sensors do not overheat at zero flow using a unique constant temperature control method and power limiting design
- Sensor lead length independent circuitry
- Completely field configurable using the local user interface or via a computer connection
- Supports HART, Profibus DP, and Modbus communication protocols
- Zero velocity as a valid data point
- Velocity-temperature mapping for wide ranging velocity and temperature
- User-defined binary gas compositions or up to five multiple gas calibrations
- Flexibility with transmitter-attached or transmitter-separate designs
- Patent US 7,418,878

Kurz Instruments is dedicated to manufacturing and marketing the best thermal mass flow meters available and to support our customers in their efforts to improve their businesses.

Applications

- Process & specialty gases
- Compressed air
- Fuel flow
- Natural gas metering
- Solvent & VOC recovery
- NOx control using ammonia
- Flow calibration
- Air sampling



Kurz Instruments, Inc.
2411 Garden Road
Monterey, CA 93940
800-424-7356
www.KurzInstruments.com



SPECIFICATIONS

- **Mass flow range**
Up to 4,000 SCFM (6,240 NCMH)
depending on model and calibration option
- **Flow accuracy** (SCFM at laboratory conditions)
 \pm (1% of reading + (A x 20 SFPM))
where A is the flow area of the 504FTB
- **0.25% reading repeatability**
- **Velocity time constant**
1 second for velocity changes at
6,000 SFPM (constant temperature)
- **Process temperature time constant**
8 seconds for temperature changes at
6,000 SFPM (constant velocity)
- **Temperature accuracy**
 \pm (0.5% of reading +1°C) for velocities above
100 SFPM
- **Electronics operating temperature**
Integral display
-13°F to 149°F (-25°C to 65°C)
Remote aluminum enclosure
-40°F to 149°F (-40°C to 65°C)
Remote polycarbonate enclosure
-13°F to 122°F (-25°C to 50°C)

PROCESS CONDITIONS

- **Process pressure rating**
Up to 300 PSIG (20 BARg)
- **Process temperature rating**
-40°F to 257°F (-40°C to 125°C)

APPROVALS

- **EPA mandatory GHG certification**
40 CFR 98.34(c)(1)
- **Alarm output conformity**
NAMUR NE43
- **CE and UKCA compliance**
EMC, LVD, PED, ROHS, and WEEE
- **Canadian Registration**
CRN
- **cETLus, ATEX, UKEX, IECEx approvals for Explosive Atmospheres protection by Flameproof and Increased Safety**
EN/IEC/UL/CSA C22.2/60079-0
EN/IEC/UL/CSA C22.2/60079-1
EN/IEC/UL/CSA C22.2/60079-7
Class I, Div. 1, Group B, C, and D
Class I, Div. 2, Group A, B, C, and D

TRANSMITTER FEATURES

- **Aluminum (Type 4, IP66) dual chamber polyester powder-coated enclosure**
- **Adjustable display/keypad orientation**
- **Optically-isolated 4-20 mA output**
12-bit resolution and accuracy
Maximum loop resistance is
500Ω at 18 V DC, 800Ω at 24 V DC,
1400Ω at 36 V DC
- **Input power**
AC (85-264 V 50/60 Hz, 24 watts max.)
or DC (24 V \pm 10%), 1 A max.
- **Solid state relays**
Optically isolated,
0.5 A, 24 V AC/DC maximum
- **Integral or remote user interface**
Easy-to-use interface
Backlit display / keypad
2-lines of 16-characters each
- **User-configurable flow display (scrolling or static)**
- **User-configurable English or metric units for mass flow rate, mass velocity, or process temperature**
°C, °F, KGH, KGM, NCMH, NLPM, NMPS, PPD, PPH, PPM, SCFH, SCFM, SCMH, SLPM
- **Two optically isolated solid-state relays / alarms**
Configurable as alarm outputs, pulsed totalizer output, or air purge cleaning
- **Built-in flow totalizers and elapsed time**
- **User-configurable digital filtering from 0 to 600 seconds**
- **Configuration/data access**
USB or RS-485 Modbus (ASCII or RTU)
- **Meter memory**
200 recent events, top 20 min/max, and
56 hours (10 second samples of trends)
- **3-year warranty**

SUPPORT & ELEMENT COMPONENTS

- **Sensor material**
C-276 alloy all-welded sensor construction
- **Sensor support**
316L stainless steel
- **Sensor flow body diameter options**
Available from 3/8" to 4"
- **Connection type**
Raised-face flange (Class 150 ANSI B16.5 or Class 300 ANSI B16.5) or MNPT pipe ends
- **3-year warranty**

OPTIONS

- **Enclosures**
Aluminum or remote-only stainless steel or polycarbonate
- **Multiple gas calibrations with up to five curves loaded in memory**
- **User-defined binary gas compositions**
- **Digital input dedicated to zero-mid-span drift check**
- **Pulsed output as a remote flow totalizer**
- **Hardware accessories**
Available hardware includes sun shades, ball valves, cable glands, conduit seals, and cable
- **Communication protocols**
HART (v7 FSK) and PROFIBUS DP
- **SIL1 certification**
via TUV Rheinland



PROCESS TEMPERATURE & COMPENSATION

Temperature influences the physical properties of gases, so temperature compensation is required for a thermal sensor to accurately measure gas flow rates.

- **Standard Temperature Compensation (STC)** is used for process temperatures from 0°C to 125°C over a moderate velocity range.
- **Velocity Temperature Mapping (VTM)** is used when the process temperature and gas velocity vary widely. Multiple velocity calibrations are stored in the meter. VTM compensation is based on air; specific gas correlations are required to ensure accuracy at high temperatures.

SPECIALTY GAS VELOCITY CALIBRATION

There are two types of gas calibration:

- **Laboratory gas calibrations** are performed with gases of high purity and are NIST traceable. Values above the calibrating facility limit are correlated up to the specified range. Customers must specify the calibration process pressure.
- **Correlation gas calibrations** are based on experimental data correlated to an Air calibration at ambient pressure and temperature. The flow element is calibrated in Air, and then an additional calibration data sheet is generated using the correlation factors. All correlation calibrations include velocity-temperature mapping.

Add $\pm 5\%$ of reading to the accuracy specification when using a correlation calibration.

For Oxygen gas, the customer is responsible for ensuring the mass flow sensor is clean of hydrocarbons and safe for Oxygen use.

ANALOG & DIGITAL INPUTS

All options include USB interface with ASCII text and Modbus protocol through RS-485.

The 4-20mA analog outputs (AO) are used for flow rate and/or temperature, or one AO for PID flow control. All AO are NAMUR NE-43 compliant.

Relay digital outputs (DO) can be alarms, EPA zero-mid-span drift is active, or pulsed totalizer function. PID uses one 4-20mA output for the flow controller. The EPA zero-mid-span drift check requires a contact closure to start the drift check. All 4-20mA outputs are used during the Drift Check Calibration process.

EPA zero-mid-span drift check can be initiated using digital inputs (DI), elapsed runtime automatic drift check, Modbus, or HART.

The 4-20mA analog input (AI) supports feedback to the device.



SERIES 504FTB OUTLINE DRAWINGS

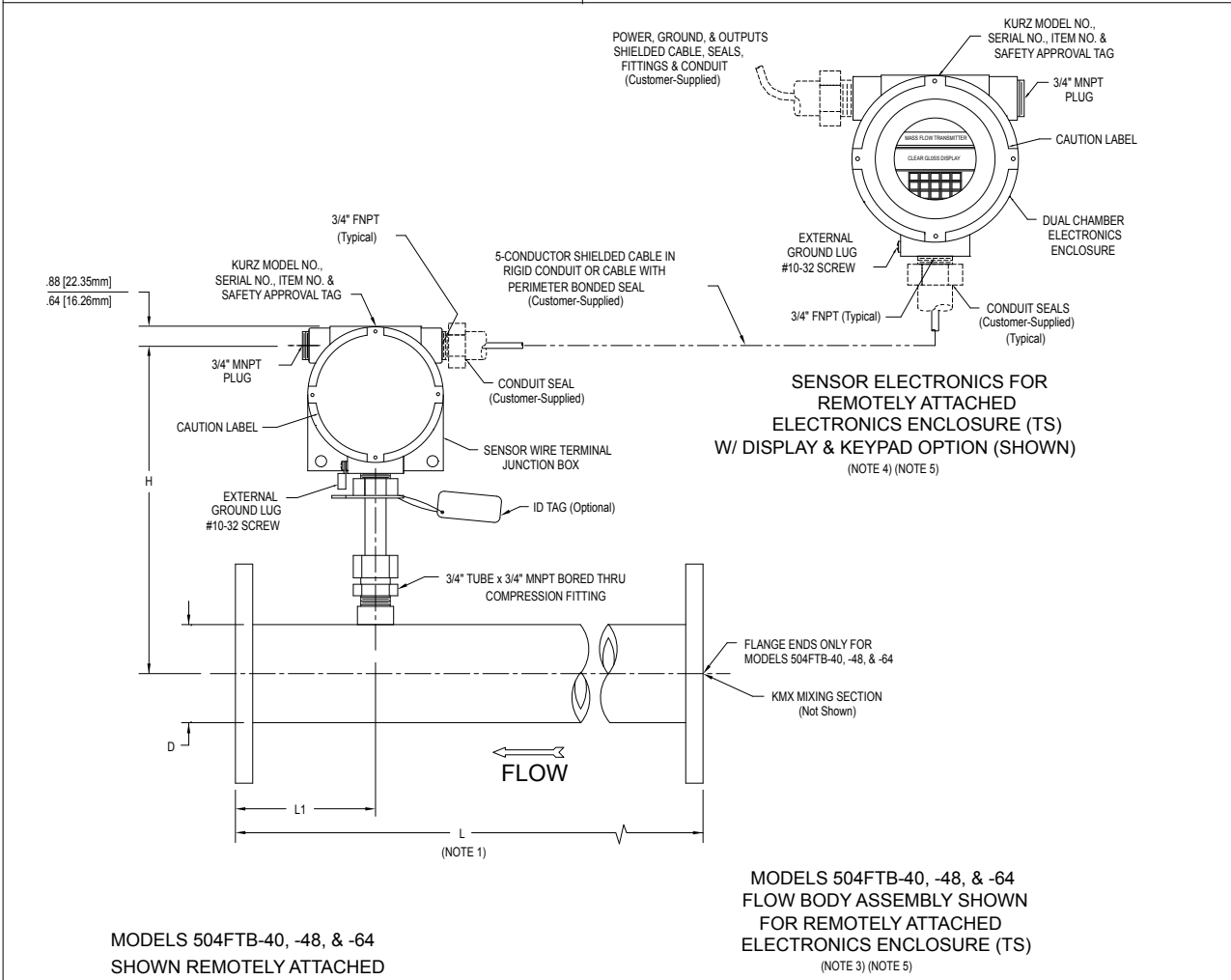
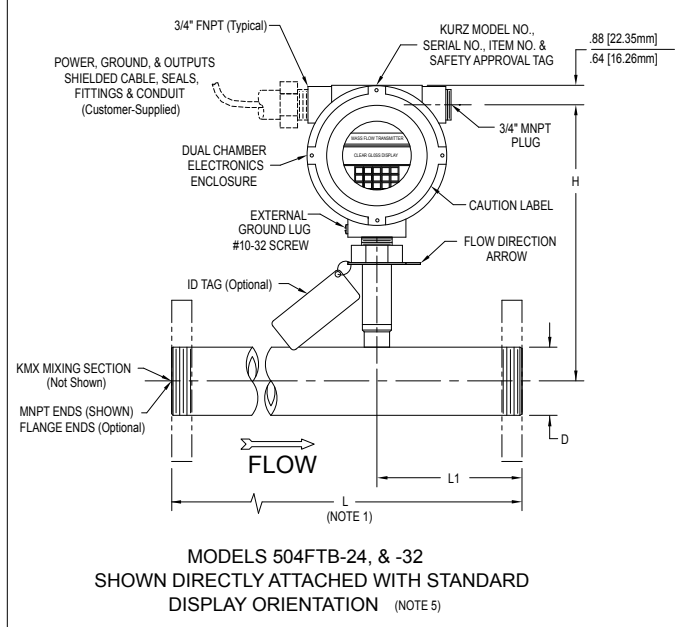
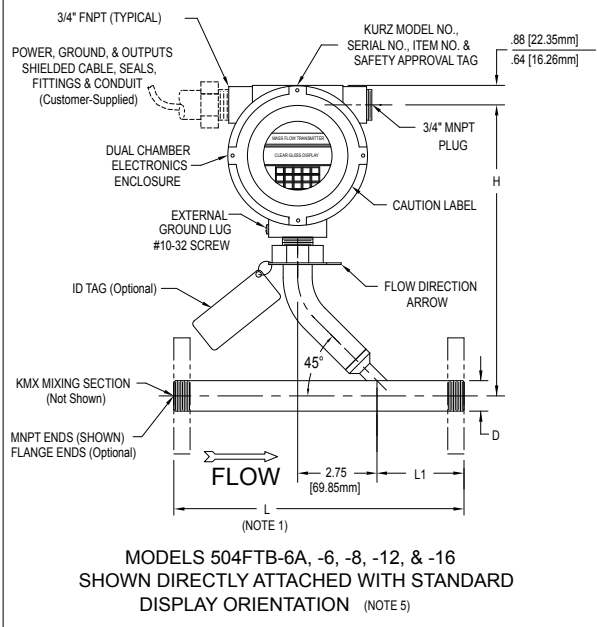

All units are in inches, unless otherwise specified.



SERIES 504FTB OUTLINE DRAWINGS (cont'd)

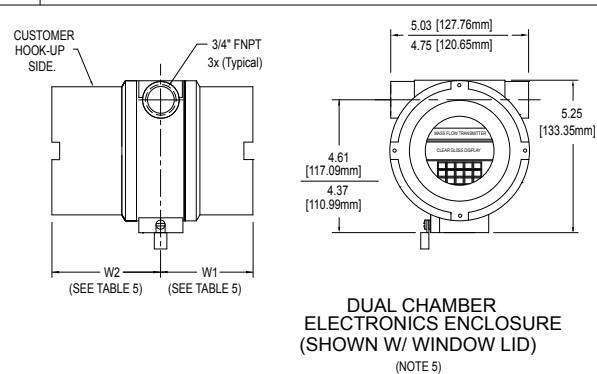
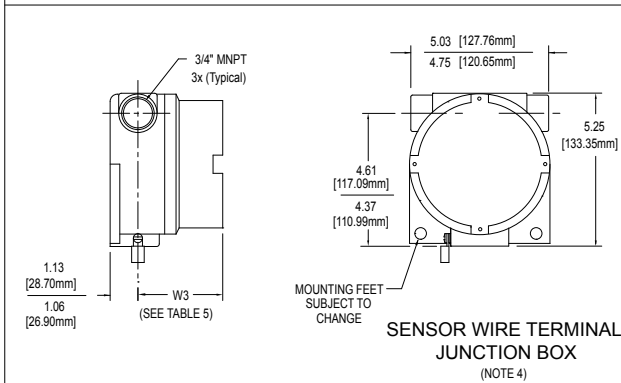
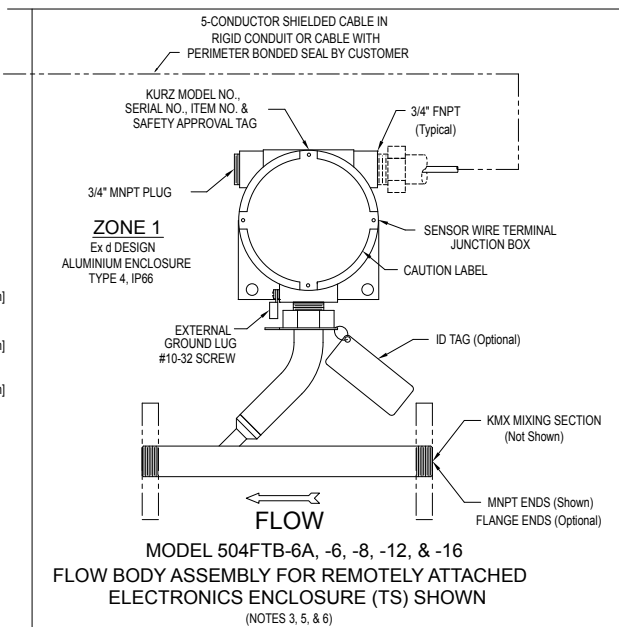
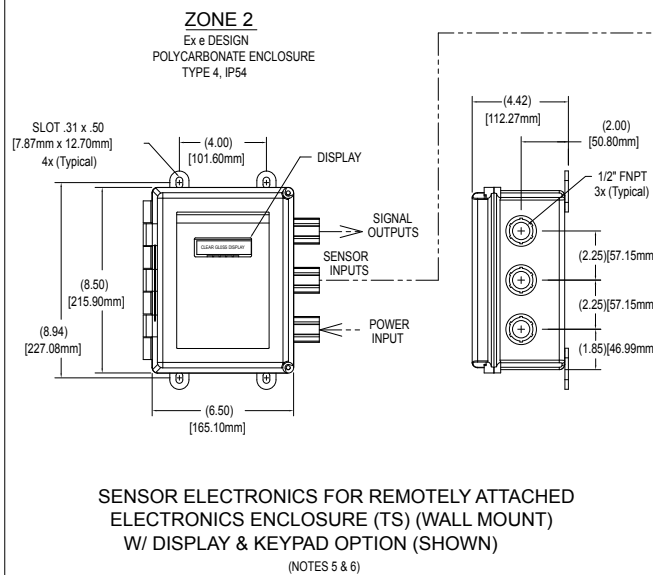

TABLE 4 SERIES 504FTB IN-LINE MASS FLOW TRANSMITTERS DIMENSIONS

MODEL NUMBER	NOMINAL PIPE SIZE (INCHES)	D INCHES [mm]	NOMINAL FLANGE SIZE (INCHES)	L (NOTE 1) INCHES [mm]	L1 INCHES [mm]	H INCHES [mm]	NET WEIGHT (APPROX.) LBS. [kg] (NOTE 2)		
							THREADED	CL150 FLANGED	CL300 FLANGED
504FTB-6A	3/8	0.675 [17.15mm]	1/2	7.00 [177.80mm]	2.50 [63.50mm]	9.94 [252.48mm]	7.00 [3.18kg]	9.00 [4.08kg]	11.00 [4.99kg]
504FTB-6	3/8	0.675 [17.15mm]	1/2	7.00 [177.80mm]	2.50 [63.50mm]	9.94 [252.48mm]	7.00 [3.18kg]	9.00 [4.08kg]	11.00 [4.99kg]
504FTB-8	1/2	0.840 [21.34mm]	1/2	8.00 [203.20mm]	3.00 [76.20mm]	10.02 [254.51mm]	7.50 [3.40kg]	9.50 [4.31kg]	11.50 [5.22kg]
504FTB-12	3/4	1.050 [26.67mm]	3/4	10.00 [254.00mm]	3.00 [76.20mm]	10.13 [257.30mm]	8.00 [3.63kg]	11.50 [5.22kg]	13.50 [6.12kg]
504FTB-16	1	1.315 [33.40mm]	1	12.00 [304.80mm]	3.50 [88.90mm]	10.25 [260.35mm]	8.50 [3.86kg]	12.50 [5.67kg]	14.50 [6.58kg]
504FTB-24	1-1/2	1.900 [48.26mm]	1-1/2	18.00 [457.20mm]	4.00 [101.60mm]	9.30 [236.22mm]	10.50 [4.67kg]	19.00 [8.62kg]	23.00 [10.43kg]
504FTB-32	2	2.375 [60.33mm]	2	24.00 [609.60mm]	5.00 [127.00mm]	9.54 [242.32mm]	14.00 [6.35kg]	24.00 [10.89kg]	30.00 [13.61kg]
504FTB-40	2-1/2	2.875 [73.03mm]	2-1/2	24.00 [609.60mm]	5.00 [127.00mm]	11.78 [299.21mm]	N/A	32.50 [14.74kg]	42.50 [19.28kg]
504FTB-48	3	3.500 [88.90mm]	3	24.00 [609.60mm]	5.00 [127.00mm]	11.78 [299.21mm]	N/A	40.00 [18.14kg]	54.00 [24.49kg]
504FTB-64	4	4.500 [114.30mm]	4	24.00 [609.60mm]	5.00 [127.00mm]	11.78 [299.21mm]	N/A	62.50 [28.35kg]	82.50 [37.42kg]

TABLE 5 ENCLOSURE DIMENSION (NOTE 5)

INPUT POWER	DISPLAY / KEYPAD	W1 (MAX.) (MIN.)	W2 (MAX.) (MIN.)	W3 (MAX.) (MIN.)
AC	YES	3.63 [92.20mm]	5.01 [127.25mm]	N/A
		3.41 [86.61mm]	4.69 [119.13mm]	
AC	NO	3.16 [80.26mm]	5.01 [127.25mm]	N/A
		2.81 [71.37mm]	4.69 [119.13mm]	
24VDC	YES	3.63 [92.20mm]	5.01 [127.25mm]	N/A
		3.41 [86.61mm]	4.69 [119.13mm]	
24VDC	NO (NOTE 4)	N/A	N/A	5.01 [127.25mm]
		N/A	N/A	4.88 [123.95mm]
SENSOR WIRE TERMINAL J-BOX (FOR REMOTE OPT.)		N/A	N/A	3.16 [80.26mm]
				2.81 [71.37mm]

NOTES:

- 1) L DIMENSION IS OVERALL END TO END.
- 2) WEIGHTS SHOWN ARE FOR DIRECTLY ATTACHED, AC POWER, WITH DISPLAY. FOR REMOTELY ATTACHED VERSIONS ADD 4.0 LBS. [1.82kg].
- 3) THIS PROBE CONFIGURATION ALSO USED FOR DIRECTLY ATTACHED, DC POWERED, NO DISPLAY.
- 4) SENSOR WIRE TERMINAL JUNCTION BOX USED FOR SENSOR ELECTRONICS, DC POWERED, NO DISPLAY.
- 5) ENCLOSURE STYLES AND DIMENSIONS ARE SUBJECT TO CHANGE.
- 6) THIS CONFIGURATIONS ALLOWS FOR PROBE ASSY TO BE MOUNTED IN ZONE 1 AREA AND FOR REMOTE ELECTRONICS TO BE MOUNTED IN ZONE 2 AREA.

All units are in inches, unless otherwise specified.



STANDARD FULL-SCALE FLOW RATES

Table A: Standard Full-Scale Flow Rate Ranges (Qmax)

Model Number	Flow Area (ft ²)	Laboratory ¹ Calibration Range		Correlated ² Calibration Range	
		SCFM	NCMH	SCFM	NCMH
504FTB-06A	0.00044	2	3.1	8	12.4
504FTB-06	0.00107	10	15.6	40	62.4
504FTB-08	0.00179	20	31	80	124
504FTB-12	0.00328	40	62	160	248
504FTB-16	0.00546	75	117	300	468
504FTB-24	0.01337	150	234	600	936
504FTB-32	0.02253	300	468	1200	1872
504FTB-40	0.03248	400	624	1600	2496
504FTB-48	0.05057	600	936	2400	3744
504FTB-64	0.08763	1000	1560	4000	6240

Note: 1. The baseline maximum flow rate for each transmitter model number.
2. Compressed air only.

SCFM Standard Cubic Feet Per Minute, Reference: 77°F, 14.69 PSIA

NCMH Normal Cubic Meters Per Hour, Reference 0°C, 760 mmHg
NCMH = 1.56 x SCFM (approximate)

ESTIMATED PRESSURE DROP

To compute the expected pressure drop for a flow rate, multiply the full scale pressure drop by the square of the flow ratio.

Table B: Estimated Pressure Drop (DPs)

Gas Type	Inches H ₂ O	mm H ₂ O	kPa
Air	30	762	7.46
Argon	40	1016	9.95
Butane	18	457	4.47
Carbon Dioxide	45	1143	11.19
Dry Ammonia	18	457	4.47
Dry Chlorine	51	1295	12.69
Ethane	18	457	4.47
Ethylene	20	508	4.97
Helium	2	51	0.49
Hydrogen	1	25	0.24
Methane	15	381	3.73
Digester Gas: 50% CH ₄ , 50% CO ₂	28	711	6.96
Digester Gas: 60% CH ₄ , 40% CO ₂	25	635	6.22
Digester Gas: 70% CH ₄ , 30% CO ₂	23	584	5.72
Nitrogen	29	737	7.21
Oxygen	33	838	8.21
Propane	14	356	3.48

Note: Estimated standard pressure drop is the end-to-end pressure drop at Standard Full-Scale Conditions listed in Table A.



755 _ _ _
Parent Number

F1

F2

F3

F4

F5

F6

F7

F8

F9

F10

Parent Number	Model	Pipe Size & Length
755960	504FTB-06A	0.375" x 7" (10 x 178 mm)
755961	504FTB-06	0.375" x 7" (10 x 178 mm)
755962	504FTB-08	0.5" x 8" (13 x 203 mm)
755963	504FTB-12	0.75" x 10" (19 x 254 mm)
755964	504FTB-16	1" x 12" (25 x 305 mm)
755965	504FTB-24	1.5" x 18" (38 x 457 mm)
755966	504FTB-32	2" x 24" (51 x 610 mm)
755967	504FTB-40	2.5" x 24" (64 x 610 mm)
755968	504FTB-48	3" x 24" (76 x 610 mm)
755969	504FTB-64	4" x 24" (102 x 610 mm)

Note: Models 504FTB-06 to 504FTB-32 use the MD sensor type.
Model s 504FTB-40 to 504FTB-64 use the FD2 sensor type.

F1	Option	Electronics Enclosure Configuration and Input Power
	A	Directly attached dual-chamber electronics enclosure, AC power, display / keypad
	B	Directly attached dual-chamber electronics enclosure, AC power, without display / keypad
	C	Directly attached dual-chamber electronics enclosure rotated 180° for viewing, AC power, display / keypad
	D	Remote dual-chamber electronics enclosure, AC power, display / keypad
	E	Remote dual-chamber electronics enclosure, AC power, without display / keypad
	F	Directly attached dual-chamber electronics enclosure, DC power, display / keypad
	G	Directly attached dual-chamber electronics enclosure rotated 180° for viewing, DC power, display / keypad
	H	Directly attached single-chamber electronics enclosure, DC power, without display / keypad
	I	Remote dual-chamber electronics enclosure, DC power, display / keypad
	J	Remote single-chamber electronics enclosure, DC power, without display / keypad
	R	Remote polycarbonate electronics enclosure, AC power, with display / keypad
	S	Remote polycarbonate electronics enclosure, AC power, without display / keypad
	T	Remote stainless steel electronics enclosure, AC power, with display / keypad
	V	Remote stainless steel electronics enclosure, AC power, without display / keypad
	W	Remote stainless steel electronics enclosure, DC power, with display / keypad
	X	Remote stainless steel electronics enclosure, DC power, without display / keypad

F2	Sensor Material / Flow Body and Flange Material
	Choose one option from each category.

Option	Sensor Material
3	C-276 alloy

Option	Flow Body and Flange Material
2	316L stainless steel

F3	Option	Flow Body Connection Type	Pressure Rating
	A	Male NPT pipe ends (MNPT)	300 PSIG
	B	Class 150 ANSI B16.5 flanges (CL150)	150 PSIG
	C	Class 300 ANSI B16.5 flanges (CL300)	300 PSIG
	G	DIN, PN16, RF flanges	16 Bar
	J	JIS10K, RF flanges	10 kg/cm ²

F4	Option	Process Temperature Compensation
	1	Standard temperature compensation over process range of -40°C to 125°C for all gases. Accuracy: $\pm (1 + 2000 \times A/F) \%$, where F = SCFM, A= flow body area (ft ²)
		Note: An accuracy specification of $\pm 0.025\%/^{\circ}\text{C} = (A^*)/(0.25 \text{ SFPM}/^{\circ}\text{C})$ should be added for temperatures above or below standard.

F5	Gas Flow Rate Calibration Data Range			
	Option	Description	Option	Description
	A	100% Qmax	I	60% Qmax
	B	95% Qmax	J	55% Qmax
	C	90% Qmax	K	50% Qmax
	D	85% Qmax	L	45% Qmax
	E	80% Qmax	M	40% Qmax
	F	75% Qmax	N	35% Qmax
	G	70% Qmax	P	30% Qmax
	H	65% Qmax	Q	25% Qmax
				Note: Refer to Tables A and B to determine the correct selection for calibration range selection.



F6 Specialty Gas Velocity Calibration			
Laboratory Calibration	Correlation Calibration	Description	
01	–	Ambient Air	
07	–	Compressed Air	
–	0K	Compressed Air (correlated to 4x full scale flow rate)	
–	56	Dry Ammonia	
08	58	Argon	
–	60	Butane	
14	64	Carbon Dioxide	
–	68	Dry Chlorine	
20	70	Ethane	
22	72	Ethylene	
26	76	Helium	
28	–	Hydrogen	
32	82	Methane	
35	85	Digester Gas	50% CH ₄ 50% CO ₂
36	86	Digester Gas	60% CH ₄ 40% CO ₂
37	87	Digester Gas	70% CH ₄ 30% CO ₂
–	8K	User-Defined Binary Gas Composition	
–	8M	One Gas Curve	
–	8N	Two Gas Curves	
–	8O	Three Gas Curves	
–	8P	Four Gas Curves	
–	8Q	Five Gas Curves	
40	90	Nitrogen	
44	94	Oxygen	
46	96	Propane	

Notes: Laboratory gas calibrations are performed with high purity gases and are NIST Traceable. Customers must specify process pressure (Feature 8). Propane to 50 PSIA, all other gases to 150 PSIA. Options 8M-8Q allow up to a 5-gas mix per curve; contact Kurz Sales Support if Hydrogen is included in the mix.

F7	Option	Safety Approval
A		Increased Safety: cETLus, ATEX, UKEX, and IECEx Aluminum enclosure Type 4, IP66 Ex ec IIC T5...T3 Gc; Class I Zone 2 AEx ec IIC T5...T3 Gc Class I Division 2, Groups A, B, C, and D DC Electronics Enclosure: Ta = -40°C to 65°C (T4) AC Electronics Enclosure: Ta = -40°C to 50°C (T4) or to 65°C: 150°C (T3) Sensing Element: Tp = -40°C to 55°C (T5) or to 130°C (T3)
	B	Flameproof: cETLus, ATEX, UKEX, and IECEx Aluminum enclosure Type 4, IP66 Ex db IIB + H2 T5...T3 Gb; Class I Zone 1 AEx db IIB + H2 T5...T3 Gb Class I Division 1, Groups B, C, and D DC Electronics Enclosure: Ta = -40°C to 65°C (T4) AC Electronics Enclosure: Ta = -40°C to 50°C (T4) or to 65°C: 150°C (T3) Sensing Element: Tp = -40°C to 45°C (T4) or to 110°C (T3)
D		Transmitter and sensing element separate (Feature 1, Options R and S only) Transmitter Protection by Increased Safety: cETLus, ATEX, UKEX, IECEx Electronics enclosure: Polycarbonate Type 4, IP54 Sensing Element Protection by Flameproof: cETLus, ATEX, UKEX, IECEx Sensor Enclosure: Aluminum Type 4, IP66 AC Electronics Enclosure: Ex ec IIC T5...T3 Gc; Class I Zone 2 AEx ec IIC T5...T3 Gc Class I Division 2, Groups A, B, C, and D Ta: -25°C to 50°C (T4) Sensor Enclosure: Ex db IIB + H2 T5...T3 Gb; Class I Zone 1 AEx db IIB + H2 T5...T3 Gb Class I Division 1, Groups B, C, and D Ta = -40°C to 75°C (T5) Sensing Element: Tp = -40°C to 45°C (T4) or to 110°C (T3)
	H	Transmitter and sensing element separate Flameproof: cETLus, ATEX, UKEX, and IECEx Electronics enclosure: Stainless Steel Type 4x, IP66 Sensor Enclosure: Stainless Steel Type 4x, IP66 Ex db IIB + H2 T5...T3 Gb; Class I Zone 1 AEx db IIB + H2 T5...T3 Gb Class I Division 1, Groups B, C, and D DC Electronics Enclosure: Ta = -40°C to 65°C (T4) AC Electronics Enclosure: Ta = -40°C to 50°C (T4) or to 65°C: 150°C (T3) Sensor Enclosure: Ta = -40°C to 75°C (T5) Sensing Element: Tp = -40°C to 45°C (T4) or to 110°C (T3)

F8	Option	Process Pressure
	----	Enter the Absolute Pressure (PSIA) rounded to a whole number. For example, a process Absolute Pressure of 14.7 PSIA, round to 15.0 and enter 015; for 150 PSIA enter 150.

F9	Option	Communications and Inputs/Outputs
	B	Standard Two 4-20mA isolated outputs
	C	Full Two 4-20mA isolated outputs, two relays, two digital inputs, one non-isolated 4-20mA input
	E	HART-1 One 4-20mA isolated output, two relays, two digital inputs, one non-isolated 4-20mA input
	H	HART-2 Two 4-20mA isolated outputs, two relays, two digital inputs, one non-isolated 4-20mA input
	K	Profibus DP Two 4-20mA isolated outputs, two relays, two digital inputs, one non-isolated 4-20mA input

F10	Option	Process Temperature
	-----	Enter the Absolute Temperature (°Rankin = °F + 460) rounded to a whole number. For example, a Process Temperature of 77°F is written as 0537 (77 + 460).
		Note: Add the letter "S" to the end of Feature 10 to include SIL1 certification via TUV Rheinland.