



USER'S GUIDE

SERIES 540 MASS FLOW CALIBRATOR

TABLE OF CONTENTS

Section 1	Description
Section 2	Principle of Operation
Section 3	Operating Instructions
Section 4	Specifications
Section 5	Maintenance
Section 6	Calibration Procedure
Section 7	Calibration Data of Units with 0-1 VDC Output
Appendix	Engineering Reference Documents

Warranty Statement

A54035001 Rev. A (Nov. 1986)

By: *N. Fahl* Date: 11-18-86
Checked by: *J. B. L.* Date: 11/18/86
Approved by: *M. Edridge* Date: 11/18/86

Kurz Instruments, Inc.
2411 Garden Road
Monterey, CA 93940
(408) 646-5911
(800) 424-7356

SECTION 1

DESCRIPTION

The Series 540 are a line of completely portable, battery-operated, highly accurate air mass flow meters used in a variety of applications such as research, air pollution monitoring, quality assurance, calibration and occupational safety & health applications. They feature a rugged, reliable flow transducer and a drop-proof readout meter with three or four easy-to-read scales.

The Model 540S has flow rate ranges of 0-.05, 0-.2, 0-1.0 and 0-3.0 standard liters per minute (SLPM). The Model 541S has flow rate ranges of 0-.05, 0-.2, 0-1.0 and 0-5.0 SLPM. The Model 543 has flow rate ranges of 0-2, 0-10 and 0-50 SLPM, and the Model 544 has flow rate ranges of 0-5, 0-15 and 0-150 SLPM. All Kurz Instruments mass flow meters are self-correcting for changes in ambient temperature and pressure, and they measure the actual flow rate over an extremely wide range of conditions.

The Series 540 provide accurate, repeatable measurement over a wide range of air flow rates with high accuracy and repeatability: $\pm 2\%$ accuracy for each full scale range and $\pm .25\%$ of full scale repeatability over the wide temperature and pressure range.

Weighing less than three pounds, the rugged, shock-resistant Series 540, with its attractive carrying case, can be carried and used anywhere. Self-contained, rechargeable nickel-cadmium batteries provide many hours of continuous operation. The Series 540 is built for ease-of-use and allows convenient air flow measurement in a large variety of applications.

Each Series 540 comes complete with a Kurz flow transducer, a 3"-long, 1/4" NPT pipe nipple for flow straightening, a hose nipple for 1/4" tubing, 15 feet of cable, readout meter, 115/230 VAC-50/60 Hz battery charger, rugged carrying case and complete operating manual. As an option (Specified: "Subscript -A"), a 0-1 VDC analog signal is available, suitable for recording. Calibration data is supplied in Section 6.

Other options include retractile cable (Specified: "Subscript-R"), and the popular and highly recommended 37mm filter cassette adaptor option (Specified: "Subscript -B"). Also available is a 47 mm pre-filter frequently used to eliminate effects of wind gusts while calibrating air samplers and virtual impactors outdoors (Specified: "Subscript -C").

SECTION 2

PRINCIPLE OF OPERATION

The mass flow transducer incorporates the unique Kurz "DuraFlo"TM temperature and flow sensor. The sensor is heated and operates as a constant-temperature thermal anemometer that responds to mass flow by sensing the cooling effect of the air as it passes over the heated sensor. The temperature sensor accurately compensates for a wide range of ambient temperature variations. The output is directly displayed in mass flow units of standard liters per minute (SLPM, referenced to 25°C and 760 mm Hg). Because the sensors are large and rugged, they are breakage resistant, insensitive to dirt and easily cleaned. The flow-through design of the transducer minimizes pressure drop and eliminates susceptibility to plugging, as is often found with capillary type thermal flow sensors.

It should be noted that both sensors are constructed of high-density aluminum oxide, wound with platinum, and have special glass coating. It is a similar construction to that used by the National Bureau of Standards for their reference platinum resistance temperature standards. This construction gives the Kurz mass flow meter extremely high repeatability.

It should also be noted that the mass flow readings of the Series 540 Portable Mass Flow Meters are referenced to standard conditions of 25°C and 760 mm Hg pressure, and, if volumetric flow rate is desired, the following relations should be used:

$$Q_{act} = Q_{ind} \times d_s/d_a$$

where,

d_s = air density at standard conditions of 25° C and 760 mm Hg,

d_a = actual air density inside the transducer,

Q_{act} = volumetric flow rate (LPM) and

Q_{ind} = indicated mass flow rate (SLPM)

SECTION 3

OPERATING INSTRUCTIONS

The Series 540 meters are shipped with the battery in a low-charge condition. Plug the charger jack into the front panel of the readout meter at the location labeled "Charger." Plug the other end of the charger into a 115 or 230 VAC socket. Be sure to change the switch built into the rear of the charger to the 230-volt position if 230 VAC is being used. Charge the unit for a period of at least one hour before operating. A charge of 12 to 16 hours is recommended to obtain a full-charge condition. The time between charges can be substantially increased if the charger is connected while operating the meter. Care should be taken, however, that the battery is not habitually recharged after expending only a small portion of its total capacity. This may introduce a "memory effect" that interferes with the full "dischargeability" of the NiCad system.

When charging the battery, be sure to have the range switch knob turned to the "Off" position. To check the battery voltage, turn the range switch knob to "Battery." For proper operating, the meter needle should be displaced to the right of the "Batt. OK" symbol on the meter scale.

To operate, plug the cable into the transducer body and into the receptacle labeled "Probe" on the front panel, preferably when the range switch is "Off." Note the markings on the flow body. **Orient the unit so air always flows from "in" to "out."** Next, turn the range switch past "Battery" to the highest flow range position; then downrange if necessary. The Portable Mass Flow Meter is now operating and will respond to the slightest air rate.

Be sure to insert the three-inch pipe on the inlet side of the flow body as noted in the previous section.

Remember to turn the range switch to "Off" when putting the system back into the carrying case. It is also suggested, to save battery time, to turn the meter off if there are long periods between measurements. If possible, operate the transducer with clean air; the use of an upstream air filter is highly recommended. This will insure long-term calibration accuracy.

Although seldom needed, the meter needle can be zeroed externally by means of the zero adjustment screw on the front panel. Make sure the flow rate is zero during this operation. For more exact zeroing, follow the calibration procedures in Section 6.

SECTION 4

SPECIFICATIONS

The specifications for the Series 540 are detailed on the following product sheet.

SECTION 5

MAINTENANCE

As with all rechargeable, nickel-cadmium battery systems, care should be taken to avoid extensive battery discharge. This maximizes battery life. Care should also be taken that a repetitive, consistent cycle of partial discharge/recharge is not imparted on the battery, since this will introduce a "memory effect," wherein the battery "remembers" its lowest point of discharge and does not efficiently operate below this point.

What typically happens in such an instance is the battery is consistently and repetitively recharged, over a period of time, after expending only a small portion of its capacity. This introduces the "memory" effect. Then, when the unit is discharged slightly below this point, it undergoes a precipitous, full discharge.

To avoid this "memory effect," it is recommended that batteries not be recharged according to a rigid time schedule, and that they be allowed to occasionally discharge the bulk of their capacity (Total capacity: approx. one volt per cell, for a total low voltage of eight volts).

Checking the battery charge is easily accomplished by switching the knob on the meter to the "BATTERY" position and observing the needle deflection. The batteries are always charged if the needle deflection exceeds the battery check mark ("BATT. OK") on the meter legend.

Although the relatively large diameter of the flow sensor renders it immune to particulate contamination in typical environments, continued use in dirty environments may necessitate periodic cleaning of the sensor. Since the sensor is quite large and rugged, this can be accomplished with a small, soft brush (such as camel's hair) and clean water, followed by an alcohol rinse. The sensor should be dry before resuming operation.

Always seal the flow sensor when not using the system to protect the sensor from contact with foreign objects or contamination. Store or transport the meter and probe in the convenient foam-padded carrying case to prevent damage due to shock.

Calibration should be checked periodically -- normally annually, depending on the accuracy of the data needed and frequency of use. The meter can be returned to:

Kurz Instruments Inc.
2411 Garden Rd.
Monterey, CA 93940

Be sure to call the factory for a Return Authorization Number prior to shipping your unit. Including all miscellaneous parts along with the name, address and phone number of user. Allow 4-6 weeks for recalibration of your portable unit.

Mass flow velocity calibration systems can be obtained from the Kurz factory. The use of this system would allow you to check your calibration or to recalibrate most portable mass flow meters -- even those of other manufacturers. Consult our factory sales engineers or our local representative about our Model 500A mass flow Calibration Systems.

SECTION 6
CALIBRATION PROCEDURE

All Kurz products are calibrated at the factory. As with any instruments, it is wise to check the calibration from time to time, preferably on a regular schedule. Unless you have an accurate flow calibration facility, it may be most convenient to have Kurz perform this function at the factory. This process can be expedited by obtaining an authorization number from Kurz's Customer Service Department prior to shipping the unit.

The mass flow calibration procedure consists of inserting the transducer in a known mass flow and adjusting the "zero" and "span" controls mounted on the circuit board inside the meter. First zero the meter by using the meter zeroing screw mounted on the front panel, with power off. Seal the end of the transducer to obtain a zero flow reading. Adjust the zero control, R22, such that the meter needle reads zero on the lowest range. After properly zeroing the instrument, the span controls, R11, R12, R13 and R14 are adjusted to obtain the full-scale readings on each of the flow scales. The flow facility must be adjusted to give the proper full-scale values for range adjustment. Zero adjustments can be made using the meter zeroing screw on the front panel if small changes become necessary.

Doc. No. C44031001 in Appendix shows a component side view of the circuit board of the mass flow meters. Shown are the potentiometers used to zero and span the various range scales of the meter. Also shown is the span potentiometer, R34, for meters having the 0-1 VDC output option.

The potentiometers labeled in Doc. No. C44031001 relate the various range scales as follows:

	540S	541S	543	544
R22	Zero adjust	Zero adjust	Zero adjust	Zero adjust
R11	3 SLPM	5 SLPM	50 SLPM	150 SLPM
R12	1 SLPM	1 SLPM	10 SLPM	50 SLPM
R13	.2 SLPM	.2 SLPM	2 SLPM	15 SLPM
R14	.05 SLPM	.05 SLPM	--	5 SLPM
R34	3 SLPM=1VDC	5 SLPM=1VDC	50 SLPM=1VDC	150 SLPM=1VDC

SECTION 7
Analog Output Data
Model 540S-A
0-1 VDC @ 0-3 SLPM

Standard Conditions:
25° C
760 mm Hg

FLOW RATE (SLPM)	OUTPUT VOLTAGE	FLOW RATE (SLPM)	OUTPUT VOLTAGE
.00	.0000	1.60	.7432
.05	.0671	1.70	.7641
.10	.1254	1.80	.7850
.15	.1767	1.90	.8050
.20	.2221	2.00	.8250
.25	.2619	2.10	.8438
.30	.2955	2.20	.8631
.35	.3274	2.30	.8824
.40	.3542	2.40	.9014
.45	.3799	2.50	.9195
.50	.4032	2.60	.9373
.55	.4252	2.70	.9540
.60	.4465	2.80	.9700
.65	.4663	2.90	.9854
.70	.4856	3.00	1.0000
.75	.5045		
.80	.5223		
.85	.5400		
.90	.5570		
.95	.5740		
1.00	.5901		
1.10	.6197		
1.20	.6481		
1.30	.6738		
1.40	.6982		
1.50	.7207		

SECTION 7
Analog Output Data
Model 540S-A
0-1 VDC @ 0-3 SLPM

Standard Conditions:
25° C
760 mm Hg

FLOW RATE (SLPM)	OUTPUT VOLTAGE	FLOW RATE (SLPM)	OUTPUT VOLTAGE
.00	.0000	1.60	.7432
.05	.0671	1.70	.7641
.10	.1254	1.80	.7850
.15	.1767	1.90	.8050
.20	.2221	2.00	.8250
.25	.2619	2.10	.8438
.30	.2955	2.20	.8631
.35	.3274	2.30	.8824
.40	.3542	2.40	.9014
.45	.3799	2.50	.9195
.50	.4032	2.60	.9373
.55	.4252	2.70	.9540
.60	.4465	2.80	.9700
.65	.4663	2.90	.9854
.70	.4856	3.00	1.0000
.75	.5045		
.80	.5223		
.85	.5400		
.90	.5570		
.95	.5740		
1.00	.5901		
1.10	.6197		
1.20	.6481		
1.30	.6738		
1.40	.6982		
1.50	.7207		

**Analog Output Data
Model 541S-A**

0-1 VDC @ 0-5 SLPM

Standard Conditions:

25° C

760 mm Hg

FLOW RATE (SLPM)	OUTPUT VOLTAGE	FLOW RATE (SLPM)	OUTPUT VOLTAGE
.0	.0000	2.6	.7076
.1	.0816	2.7	.7217
.2	.1576	2.8	.7345
.3	.2104	2.9	.7475
.4	.2527	3.0	.7608
.5	.2892	3.1	.7736
.6	.3224	3.2	.7858
.7	.3557	3.3	.7986
.8	.3855	3.4	.8114
.9	.4128	3.5	.8236
1.0	.4380	3.6	.8358
1.1	.4626	3.7	.8485
1.2	.4847	3.8	.8603
1.3	.5047	3.9	.8722
1.4	.5244	4.0	.8844
1.5	.5421	4.1	.8958
1.6	.5592	4.2	.9082
1.7	.5759	4.3	.9195
1.8	.5926	4.4	.9313
1.9	.6081	4.5	.9427
2.0	.6231	4.6	.9540
2.1	.6380	4.7	.9656
2.2	.6532	4.8	.9768
2.3	.6667	4.9	.9884
2.4	.6806	5.0	1.0000
2.5	.6950		

Analog Output Data
Model 543-A

0-1 VDC @ 0-50 SLPM

Standard Conditions:

25°C

760 mm Hg

FLOW RATE (SLPM)	OUTPUT VOLTAGE	FLOW RATE (SLPM)	OUTPUT VOLTAGE
0	.000	26	.785
1	.185	27	.796
2	.263	28	.806
3	.318	29	.817
4	.364	30	.827
5	.402	31	.836
6	.437	32	.846
7	.468	33	.856
8	.496	34	.865
9	.522	35	.875
10	.547	36	.883
11	.566	37	.891
12	.585	38	.900
13	.604	39	.909
14	.622	40	.918
15	.640	41	.926
16	.655	42	.934
17	.669	43	.942
18	.684	44	.951
19	.699	45	.960
20	.714	46	.968
21	.726	47	.975
22	.738	48	.982
23	.750	49	.994
24	.762	50	1.000
25	.775		

**Analog Output Data
Model 543-A**

0-1 VDC @ 0-50 SLPM

Standard Conditions:

25° C

760 mm Hg

FLOW RATE (SLPM)	OUTPUT VOLTAGE	FLOW RATE (SLPM)	OUTPUT VOLTAGE
0	.000	26	.785
1	.185	27	.796
2	.263	28	.806
3	.318	29	.817
4	.364	30	.827
5	.402	31	.836
6	.437	32	.846
7	.468	33	.856
8	.496	34	.865
9	.522	35	.875
10	.547	36	.883
11	.566	37	.891
12	.585	38	.900
13	.604	39	.909
14	.622	40	.918
15	.640	41	.926
16	.655	42	.934
17	.669	43	.942
18	.684	44	.951
19	.699	45	.960
20	.714	46	.968
21	.726	47	.975
22	.738	48	.982
23	.750	49	.994
24	.762	50	1.000
25	.775		

**Analog Output Data
Model 544-A
Portable Mass Flow Calibrator**

0-1 VDC @ 0-150 SLPM

**Standard Conditions:
25°C
760 mmHg**

FLOW RATE (SLPM)	OUTPUT VOLTS D.C.	FLOW RATE (SLPM)	OUTPUT VOLTS D.C.
0	.000	38	.617
1	.100	40	.628
2	.158	45	.654
3	.196	50	.678
4	.228	55	.700
5	.260	60	.721
6	.280	65	.742
7	.301	70	.761
8	.321	75	.780
9	.334	80	.797
10	.355	85	.814
12	.386	90	.831
14	.414	95	.846
16	.439	100	.862
18	.462	105	.877
20	.482	110	.892
22	.501	115	.906
24	.518	120	.920
26	.535	125	.934
28	.550	130	.947
30	.566	135	.961
32	.579	140	.974
34	.592	145	.988
36	.605	150	1.000

APPENDIX

-Portable Schematic Diagram (#C44030001)

-Portable Component Diagram (#C44031001)

-Bill of Material for:

-Model 540S (#A54045007)

-Model 541S (#A54045008)

-Model 543 (#A54045009)

-Model 544 (#A54045010)

REVISIONS			
LTR	DESCRIPTION	DATE	APPROVED

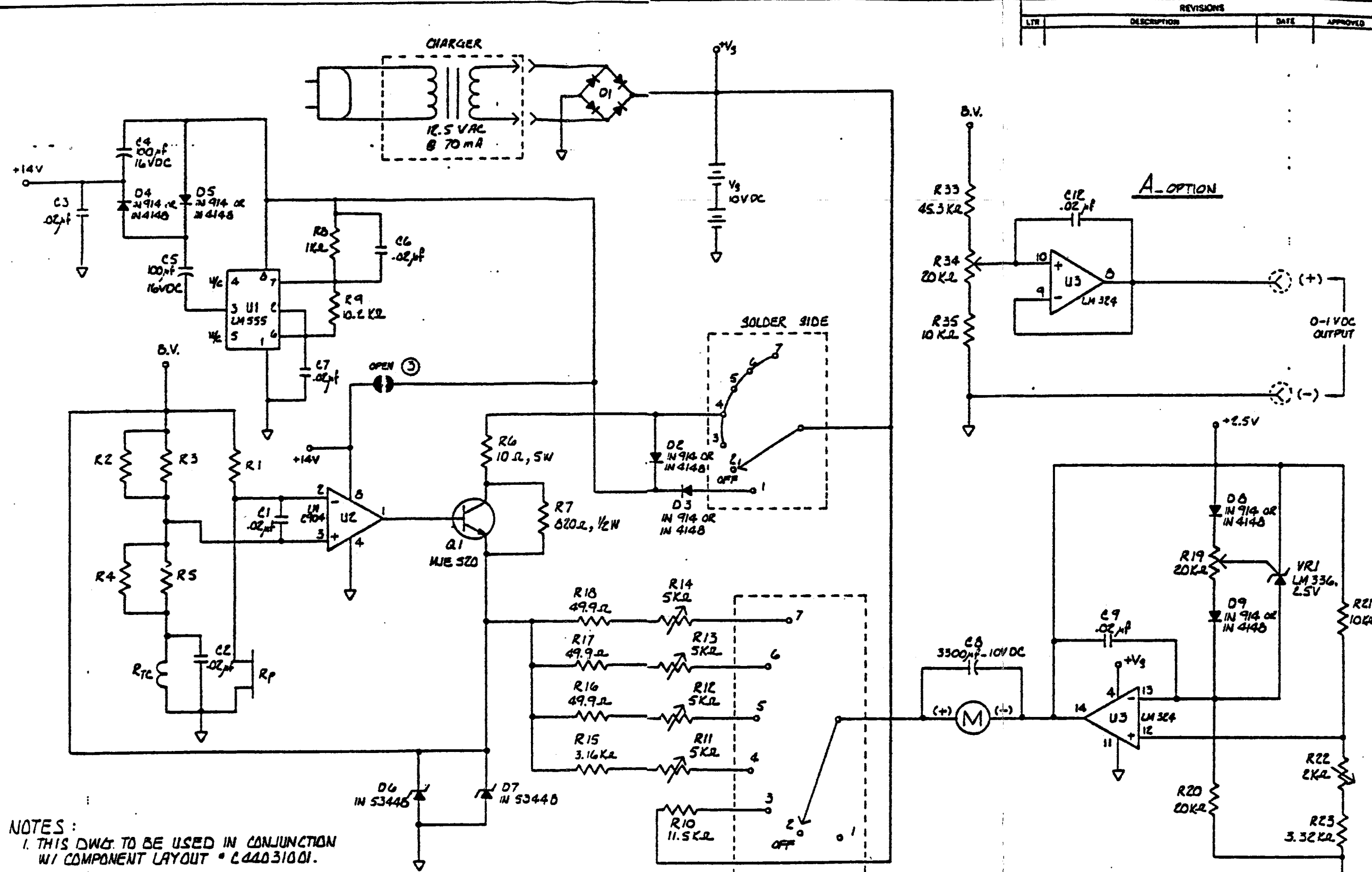

NOTES:
 1. THIS DWG. TO BE USED IN CONJUNCTION
 W/ COMPONENT LAYOUT # C44031001.

REF. DES. TABLE	
LAST USED	NOT USED
U3	
VR2	VR2
D3	D2, 3
C12	C10, 11
D11	D10, 11
R35	R24-32

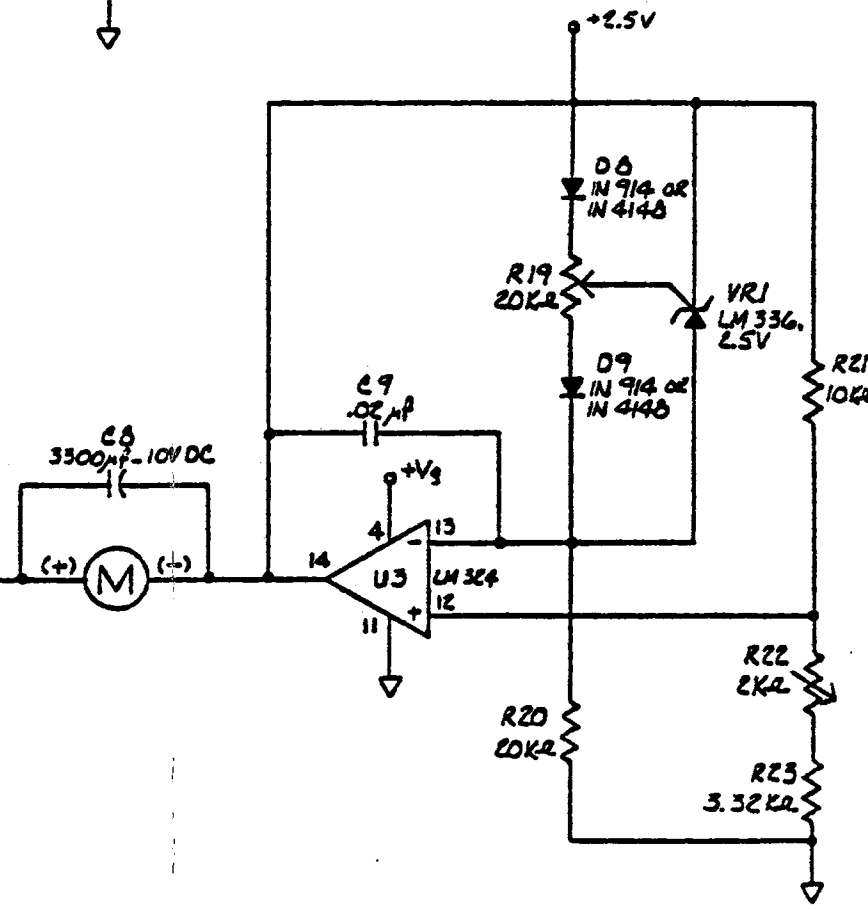
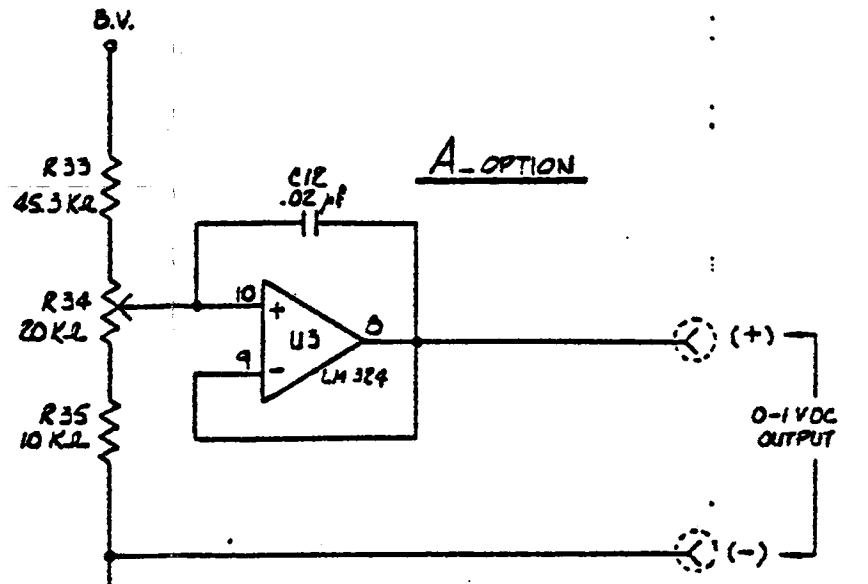

APPROVALS		DATE	KURZ INSTRUMENTS INC.	
			SERIES 440R1	
			SCHEMATIC DIAGRAM	
			SCALE	SIZE C DRAWING NO. C44030001
DO NOT SCALE DRAWING			SHEET 02 / 01	

VIEW A-A
SCALE: 2:1
SWITCHCRAFT

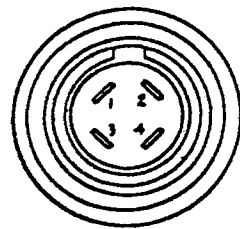

1: GREEN
2: RED
3: BLACK

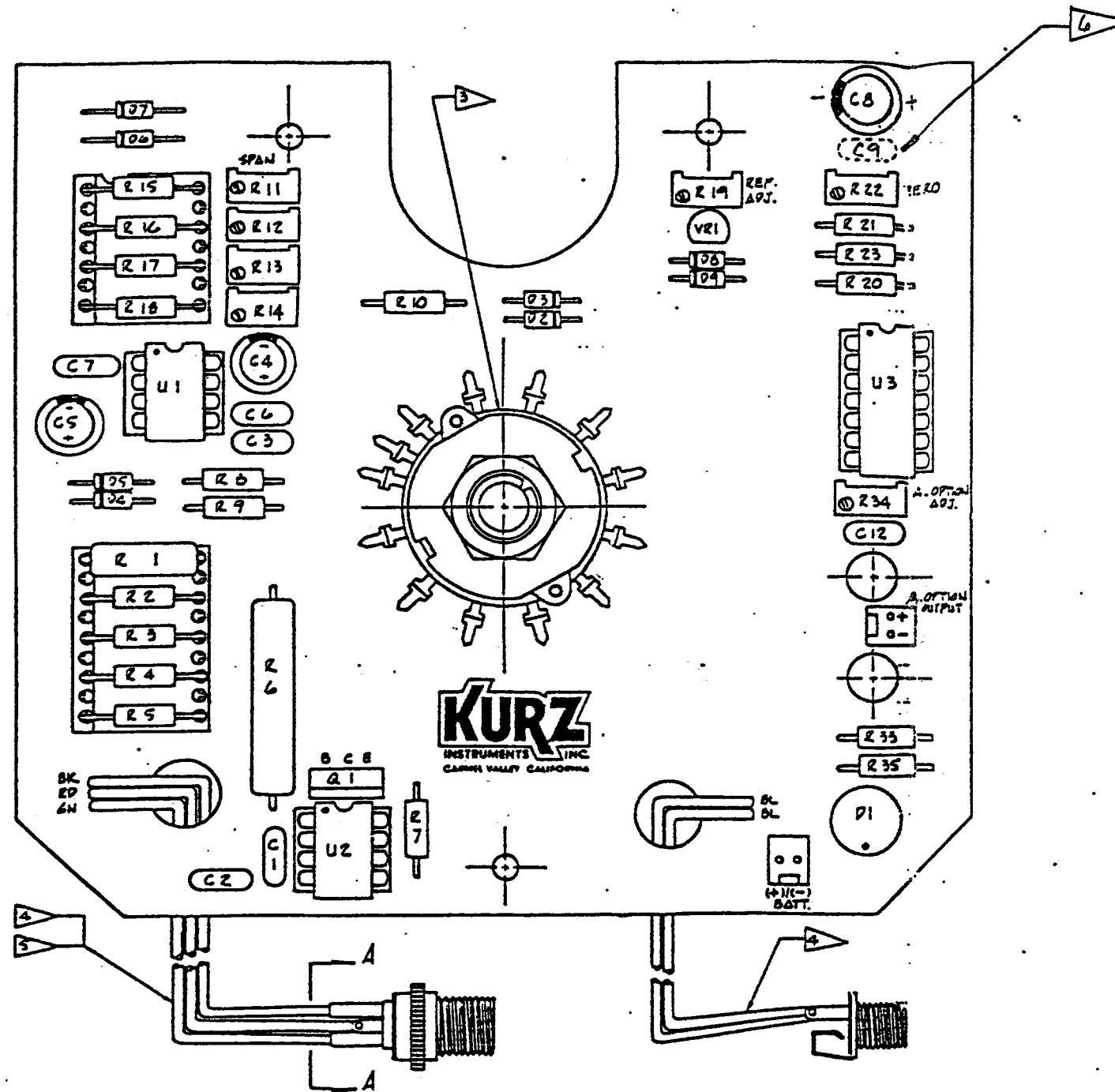

NOTES: UNLESS OTHERWISE SPECIFIED

1. THIS UNIT TO BE USED IN CONJUNCTION W/ SCHEMATIC DIAGRAM - C44030001.
2. LAST REF. PEG. USED ARE: U3, Q1, V1, C12, Q9, R35.
3. SEE DRAW. # B70002 FOR SWITCH ASST.
4. WIRES SHALL BE #22 AWG. AND APPROX. 5 IN. LONG TWISTED TOGETHER.
5. HEATSHRINK TO BE USED ON REF. BLACK WIRES OF SWITCHCRAFT (PIN 2 AND 3) WIRE LENGTH = .500 IN.
6. C9 TO BE ASSEMBLED ON THE SOLDER SIDE OF P.C. BOARD.

REF. PEG.	DESCRIPTION	QTY.
R34	POTENTIOMETER 20KΩ	1
R35	RESISTOR 10KΩ	1
R33	RESISTOR 49.5KΩ	1
C12	CAPACITOR .02μF	1
	MYLAR MALE CONNECTOR #22-23-2021	1
REF. PEG.	DESCRIPTION	QTY.
OPTION A PARTS LIST		

REVISIONS			
REF.	DESCRIPTION	DATE	APPROVED
A	ELIMINATED ONE MYLAR CAP. C8 CHANGED FROM 100μF TO 3300μF-10V. NOTE 6 ADDED	2-26-86	AQ/DT/ RJB

REF. PEG.	DESCRIPTION	QTY.
C8	CAPACITOR 3300μF-10V	1
R22	POTENTIOMETER 2KΩ	1
R19	POTENTIOMETER 20KΩ	1
R11-14	POTENTIOMETER 5KΩ	4
R23	RESISTOR 3.32KΩ	1
R21	10KΩ	1
R20	2KΩ	1
R17,18	49.9KΩ	2
R16	49.9KΩ	1
R15	3.16KΩ	1
R10	11.5KΩ	1
R9	10.2KΩ	1
R8	1KΩ	1
R7	820Ω, 1/4 W	1
R6	2.5Ω, 5W METAL	1
R1-5	RESISTOR SELECTED (TEMP. COMP.)	5
C4,5	CAPACITOR 100μF-16VDC	2
C1,2,3,4,7,9	CAPACITOR .02μF	6
Q6,7	DIODE IN 5346 B	2
Q2-5, Q8-9	DIODE IN 414 OR IN 4140	6
Q1	BRIDGE RECTIFIER # C5C B203	1
Q1	TRANSISTOR MJE 520	1
V1	VOLTAGE REGULATOR LM 336, 2.5V	1
U3	I.C. OP-AMP LM 324	1
U2	I.C. OP-AMP LM 358 OR LM 2904	1
U1	I.C. 555 TIMER	1
	16 PIN DIP SOCKET #IC-618-500	1
	16 PIN ADAPTOR PLUG #AP-618-6-C	1
	14 PIN DIP SOCKET #IC-614-500	1
	14 PIN ADAPTOR PLUG #AP-614-6-C	1
	14 PIN DIP SOCKET	1
	8 PIN DIP SOCKET	2
	MYLAR 2 PIN MALE CONNECTOR #22-23-2021	1
	SWITCHCRAFT # 2504 PR	1
	CHARGER JACK # 41	1
	• WAFER # B5100-01 AND # B5100-02	
	• ADJ. STOP # 212 (2)	
	• #4-40 #1/2" SCREW (2)	
	• NUT - WASHER # 4371	
	• SWITCH # B5127-01 AND HARDWARE :	1
	ANALOG PORTABLE PCB	1
REF. PEG.	DESCRIPTION	QTY.
PARTS LIST		

TOLERANCES UNLESS OTHERWISE SPECIFIED FRACTIONS USE ANGLES

Kurz Instruments Inc.

SERIES 44CR1 Analog Portable
Components Layout

APPROVALS: [Signature] DATE: 7-31-85

CONTR. BY: [Signature] DATE: 10-21-84

SCALE: 2:1

SIZE: C DRAWING NO. C44031001

DO NOT SCALE DRAWING SHEET 1 OF 1

WARRANTY STATEMENT

The Company's products are warranted to be free from defects in material and workmanship for one year from date of shipment from the factory. The Company's obligation is limited to repairing, or, at their option, replacing products and components which, on verification at the factory in Monterey, Calif., prove to be defective. The Company shall not be liable for installation charges, for expenses of Buyer for repairs or replacement, for damages from delay or loss of use, or other indirect or consequential damages of any kind. The Company extends this warranty only upon proper use and/or installation of the product in the applicaiton for which intended and does not cover products which have been modified without the Company's approval or which have been subjected to unusual physical or electrical stress, or upon which the original identification marks have been removed or altered.

Whenever the design of the equipment to be furnished or the system in which it is to be incorporated originate with the buyer, manufacturer's warranty is limited specifically to matters relating to furnishing of equipment free of defects in material and workmanship and assumes no responsibility for implied warranties of fitness for purpose or use.

Transportation charges for material shipped to the factory for warranty repair are to be paid by the shipper. The company will return items repaired or replaced under warranty prepaid. No items shall be returned for warranty repair without prior authorization from the Company.

ITEM	QTY	DESCRIPTION	STOCK No.	MANUF. PART No.	KURZ DWG. No.	VENDOR	REMARKS	COST
1	1	PORTABLE INSTRUMENT CASE	PRT0700		B51002			
2	1	SWITCH KNOB						
3	2	NI-CAD BATTERY	BATT0060	#402-734-000		SAFT		
4	1	SWITCH	SWT0140	#85127-01				
5	1	WAFER	SWT0132	#CS-85100-01				
6	1	WAFER	SWT0133	#CS-85100-02				
7	2	PROT. SWT SHAFT LOCK	SWT0160	#212				
8	2	#4-40x1/2" PROT. SWT SCR						
9	1	SWITCH NUT & WASHER		#45T1				
10	2	#4-40x1/4" BLK BUTTON SCR	HWD0100					
11	3	#4-40x3/4" STANDOFF						
12	3	#4-40x1/4" FLAT HD SCR						
13	2	#4-40x1/4" PAN HD SCR						
14	1	CHARGER 120V/240V	PWR0040					
15	1	SWITCHCRAFT FEMALE	CON0060					
16	1	CHARGER JACK SWITCHCRAFT	CON0065					
17	1	METER						
18	1	METER SCALE	PRT0400					
19	1	FACE PLATE	PRT0210					

SUB - TOTAL



BILL OF MATERIAL

PREP: *Ph...* 5-9-86 MODEL: 540S

CHKD:

SHT 1 OF 2 REV. 0

APVD:

BOM No. A54045007

REVISIONS

ITEM	QTY	DESCRIPTION	STOCK No.	MANUF. PART No.	KURZ DWG. No.	VENDOR	REMARKS	COST
20	1	SERIES 440R1 P.C. BOARD			C44031001			
21	1	CARRYING CASE						
22	1	SHORT CAN	ENC0150					
23	1	MASSFLOW TRANSDUCER			B20028			
24	1	NIPPLE 1/4" NPT X 3"	NIP0030					
25	1	47 ^{mm} LEXAN FILTER	FILT0230					

PREP: *Quote* SHT 2 OF 2 REV. 0
BOM No. A54045007

ITEM	QTY	DESCRIPTION	STOCK No.	MANUF. PART No.	KURZ DWG. No.	VENDOR	REMARKS	COST
1	1	PORTABLE INSTRUMENT CASE	PRT0700		B51002			
2	1	SWITCH KNOB	PRT0660					
3	2	NI-CAD BATTERY	BATT0060	#402-734-000		SAFT		
4	1	SWITCH	SWT0140	#85127-01				
5	1	WAFER	SWT0132	#CS-85100-01				
6	1	WAFER	SWT0133	#CS-85100-02				
7	2	PROT. SWT SHAFT LOCK	SWT0160	#212				
8	2	#4-40x1/2" PROT. SWT SCR						
9	1	SWITCH NUT & WASHER		#45T1				
10	2	#4-40x1/4" BLK BUTTON SCR	HWDO100					
11	3	#4-40x3/4" STANDOFF						
12	3	#4-40x1/4" FLAT HD SCR						
13	2	#4-40x1/4" PAN HD SCR						
14	1	CHARGER 120V/240V	PWR0040					
15	1	SWITCHCRAFT FEMALE	CON0060					
16	1	CHARGER JACK SWITCHCRAFT	CON0065					
17	1	METER						
18	1	METER SCALE	PRT0410					
19	1	FACE PLATE	PRT0220					
							SUB - TOTAL	



BILL OF MATERIAL

PREP : *Alison* MODEL: 541S
 CHKD : S-9-86 SHT 1 OF 2 REV. 0
 APVD : BOM No. A54045008

REVISIONS

ITEM	QTY	DESCRIPTION	STOCK No.	MANUF. PART No.	KURZ DWG. No.	VENDOR	REMARKS	COST
20	1	SERIES 440R1 P.C. BOARD			C44031001			
21	1	CARRYING CASE						
22	1	SHORT CAN	ENC0150					
23	1	MASSFLOW TRANSDUCER			B20028			
24	1	NIPPLE 1/4" NPTx3"	NIP0030					
25	1	47 ^{mm} LEXAN FILTER	FILT0230					

PREP: *Mania*

SHT 2 OF 2

REV. 0

BOM No. A54045008

910380T860401

ITEM	QTY	DESCRIPTION	STOCK No.	MANUF. PART No.	KURZ DWG. No.	VENDOR	REMARKS	COST
1	1	PORTABLE INSTRUMENT CASE	PRT0700		B51002			
2	1	SWITCH KNOB	PRT0660					
3	2	NI-CAD BATTERY	BATT0060	#402-734-000		SAFT		
4	1	SWITCH	SWT0140	#85127-01				
5	1	WAFER	SWT0132	#CS-85100-01				
6	1	WAFER	SWT0133	#CS-85100-02				
7	2	PROT. SWT SHAFT LOCK	SWT0160	#212				
8	2	#4-40x1/2" PROT. SWT SCR						
9	1	SWITCH NUT & WASHER		#45T1				
10	2	#4-40x1/4" BLK BUTTON SCR	HWD0100					
11	3	#4-40x3/4" STANDOFF						
12	3	#4-40x1/4" FLAT HD SCR						
13	2	#4-40x1/4" PAN HD SCR						
14	1	CHARGER 120V/240V	PWR0040					
15	1	SWITCHCRAFT FEMALE	CON0060					
16	1	CHARGER JACK SWITCHCRAFT	CON0065					
17	1	METER						
18	1	METER SCALE	PRT0420					
19	1	FACE PLATE	PRT0230					
							SUB - TOTAL	



BILL OF MATERIAL

PREP: *Spencer* MODEL: 543
 CHKD: SHT 1 OF 2 REV. 0
 APVD: BOM No. A54045009

REVISIONS

ITEM	QTY	DESCRIPTION	STOCK No.	MANUF. PART No.	KURZ DWG. No.	VENDOR	REMARKS	COST
20	1	SERIES 443R1 P.C. BOARD			C44331005			
21	1	CARRYING CASE						
22	1	SHORT CAN	ENC0150					
23	1	MASSFLOW TRANSDUCER			B20028			
24	1	NIPPLE 1/4" NPT x 3"	NIP0030					
25	1	47 ^{mm} LEXAN FILTER	FILT0230					

PREP: *Wish* SHT 2 OF 2 REV. 1
 BOM No. A54045009

A1023BDT260401

ITEM	QTY	DESCRIPTION	STOCK No.	MANUF. PART No.	KURZ DWG. No.	VENDOR	REMARKS	COST
1	1	PORTABLE INSTRUMENT CASE	PRT0700		B51002			
2	1	SWITCH KNOB	PRT0660					
3	2	NI-CAD BATTERY	BATT0060	#402-734-000		SAFT		
4	1	SWITCH	SWT0140	#85127-01				
5	1	WAFER	SWT0132	#CS-85100-01				
6	1	WAFER	SWT0133	#CS-85100-02				
7	2	PROT. SWT SHAFT LOCK	SWT0160	#212				
8	2	#4-40x1/2" PROT. SWT SCR						
9	1	SWITCH NUT & WASHER		#45T1				
10	2	#4-40x1/4" BLK BUTTON SCR	HWD0100					
11	3	#4-40x3/4" STANDOFF						
12	3	#4-40x1/4" FLAT HD SCR						
13	2	#4-40x1/4" PAN HD SCR						
14	1	CHARGER 120V/240V	PWR0040					
15	1	SWITCHCRAFT FEMALE	CON0060					
16	1	CHARGER JACK SWITCHCRAFT	CON0065					
17	1	METER						
18	1	METER SCALE	PRT0430					
19	1	FACE PLATE	PRT0240					
							SUB - TOTAL	

KURZ
INSTRUMENTS, INC.

BILL OF MATERIAL

PREP: *Allen* 5-9-86 MODEL: 544
 CHKD: _____ SHT 1 OF 2 REV. 0
 APVD: _____ BOM No. A54045010

REVISIONS

ITEM	QTY	DESCRIPTION	STOCK No.	MANUF. PART No.	KURZ DWG. No.	VENDOR	REMARKS	COST
20	1	SERIES 444R1 P.C. BOARD			C44431013			
21	1	CARRYING CASE						
22	1	SHORT CAN	ENCO150					
23	1	FLOW METER			A20051			
24	1	47 ^{mm} LEXAN FILTER	FILT0230					

PREP: *Quora* S-9-86 SHT 2 OF 2 REV. 0
BOM No. A54045010